

New Scale-Up Technologies For Hydrogenation Reactions in Multipurpose Plants



Siegfried

Project Partner



FORSCHUNGSFONDS
AARGAU

Project Sponsor

MiniPlant  **4.0**
Innovative Process Technology

ThinkTank

Table of contents

- **Introduction**
A. Zogg
- **Example application: Hydrogenation reactions**
T. Furrer
- **Outlook: Digital Process Lab**
A. Zogg

Research to Production

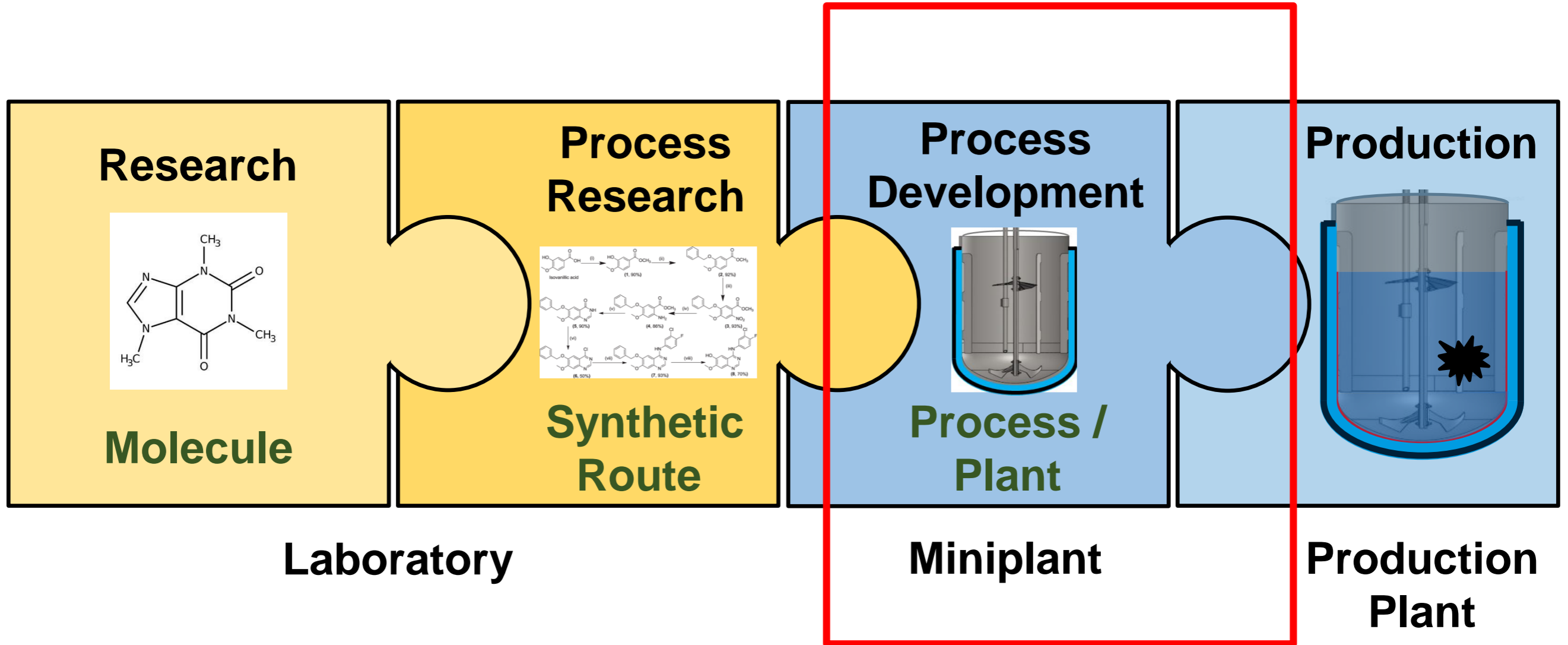

Scale-Up Today

Standard processes in Multi-Purpose Plants

Laboratory: 0.1 ... 1 l

Pilot: 10 ... 100 l

Production: 1'000 ... 10'000 l

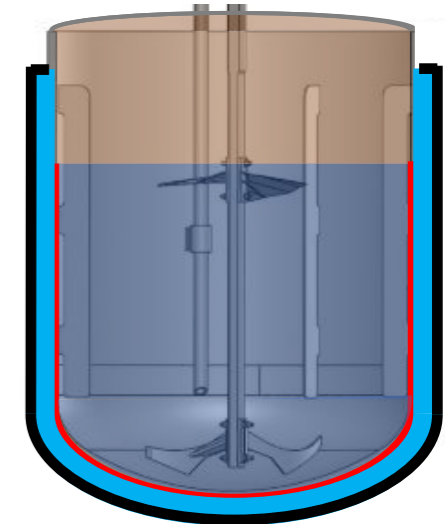
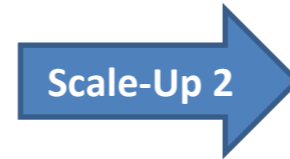
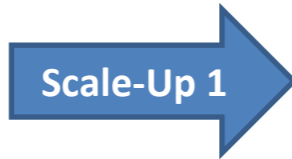

Scale-Up Tomorrow = Main goal of the project

Scale-Down-Reactor
1... 10 l

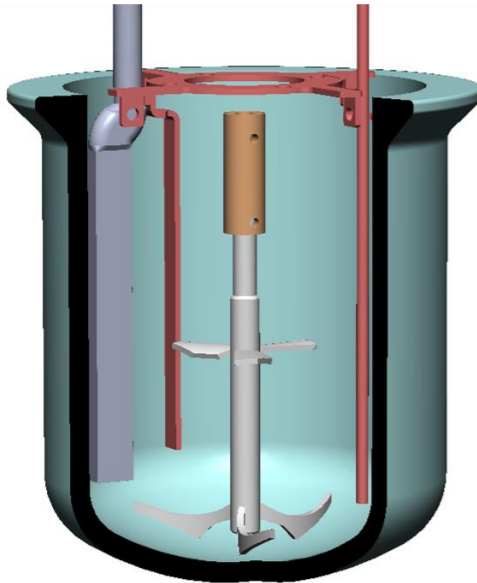

Direct Scale-Up

Production
1'000... 10'000 l

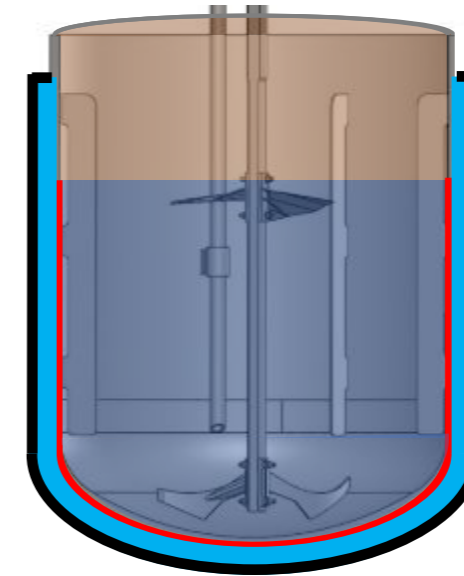

- ▶ Geometrical similarity (bottom, stirrer, baffles) → similar mass transport.
- ▶ **Challenge: Scale up of the heat transfer!**

Standard approach for the scale-up of the heat transfer

Standard Lab-Reactor: 1 l

heat exchange via glass jacket

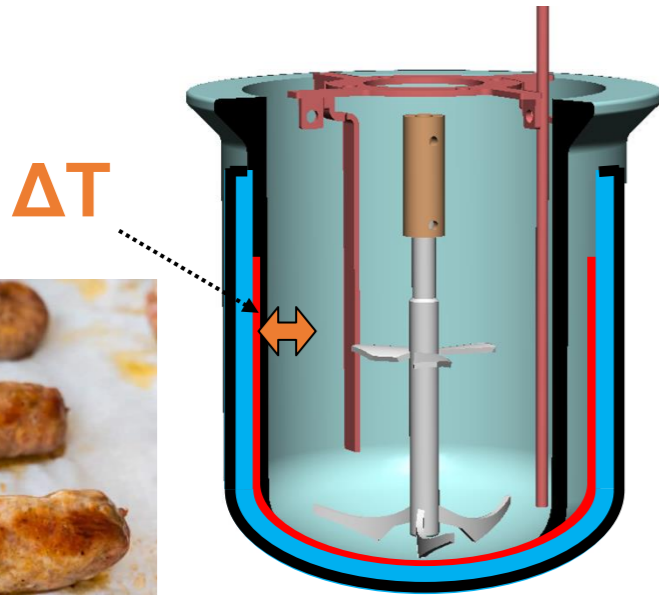

Direct Scale-Up ?

$$\dot{q} = 10 \frac{W}{l}$$

Production: 4'000 l

heat exchange via jacket

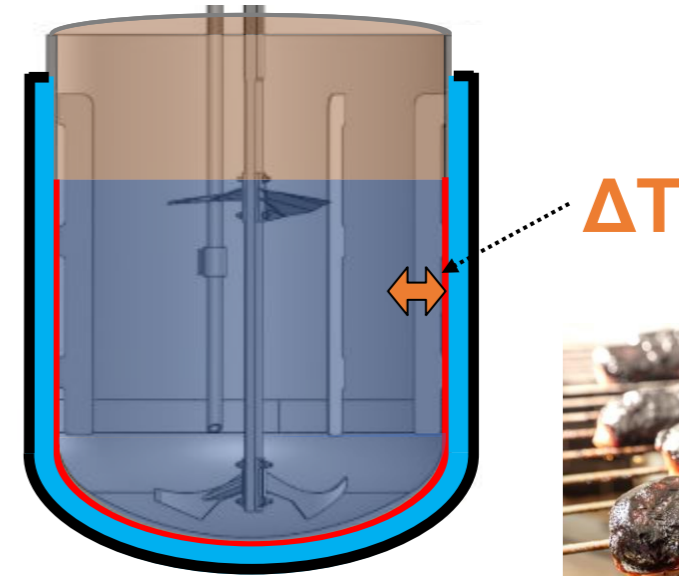

$$\frac{\text{Heat transfer area}}{\text{Volume}} : 39 \text{ m}^2/\text{m}^3$$

$$\Delta T : 0.8 \text{ K}$$

$$2.8 \text{ m}^2/\text{m}^3$$

$$12 \text{ K}$$

New approach for the scale-up of the heat transfer

Scale-Down-Reactor: 1 l
Heat exchange via H/C-Finger

Production: 4'000 l
heat exchange via jacket

Adiabatic Shield

Direct Scale-Up

$$\dot{q} = 10 \frac{W}{l}$$

Heat transfer area
Volume : 2.8 m²/m³

ΔT : 12 K

2.8 m²/m³

12 K

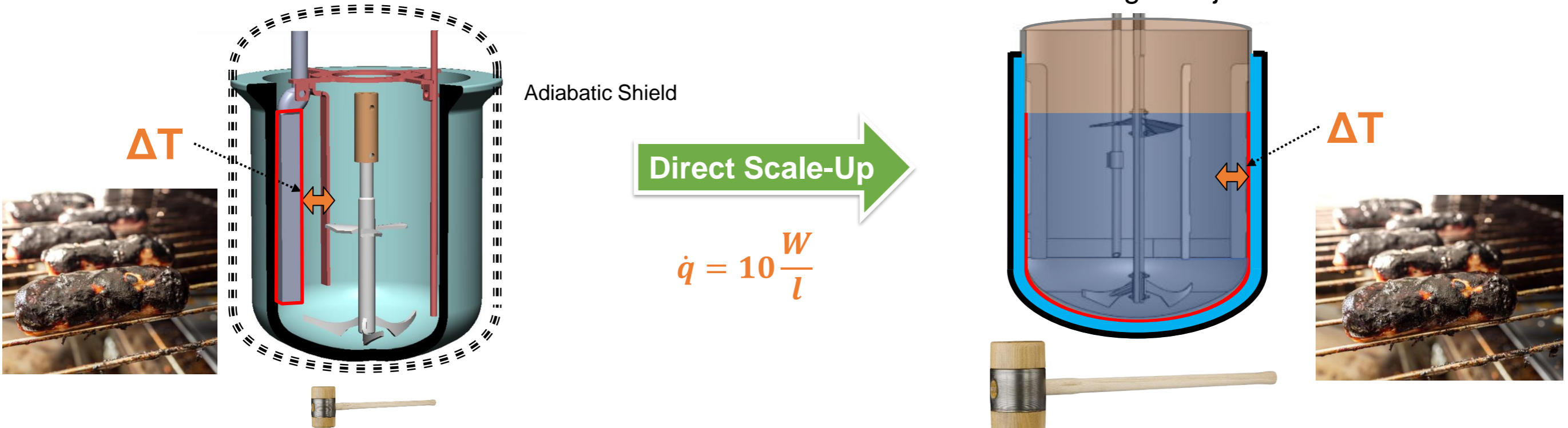

- **Introduction**
A. Zogg
- **Example application: Hydrogenation reactions**
T. Furrer
- **Outlook: Digital Process Lab**
A. Zogg

Hydrogenation reactions

Batch reactor

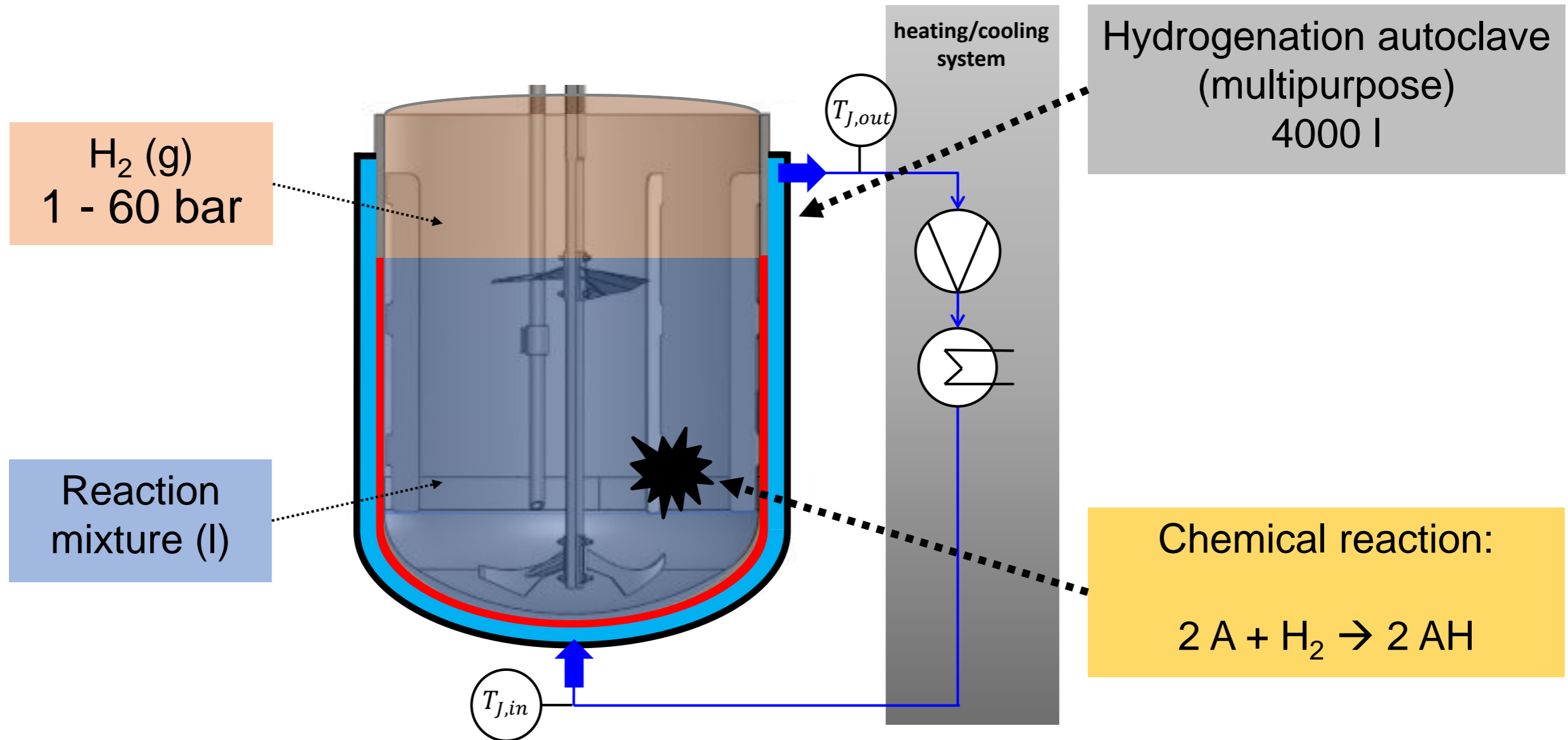

Scale-Up Strategy

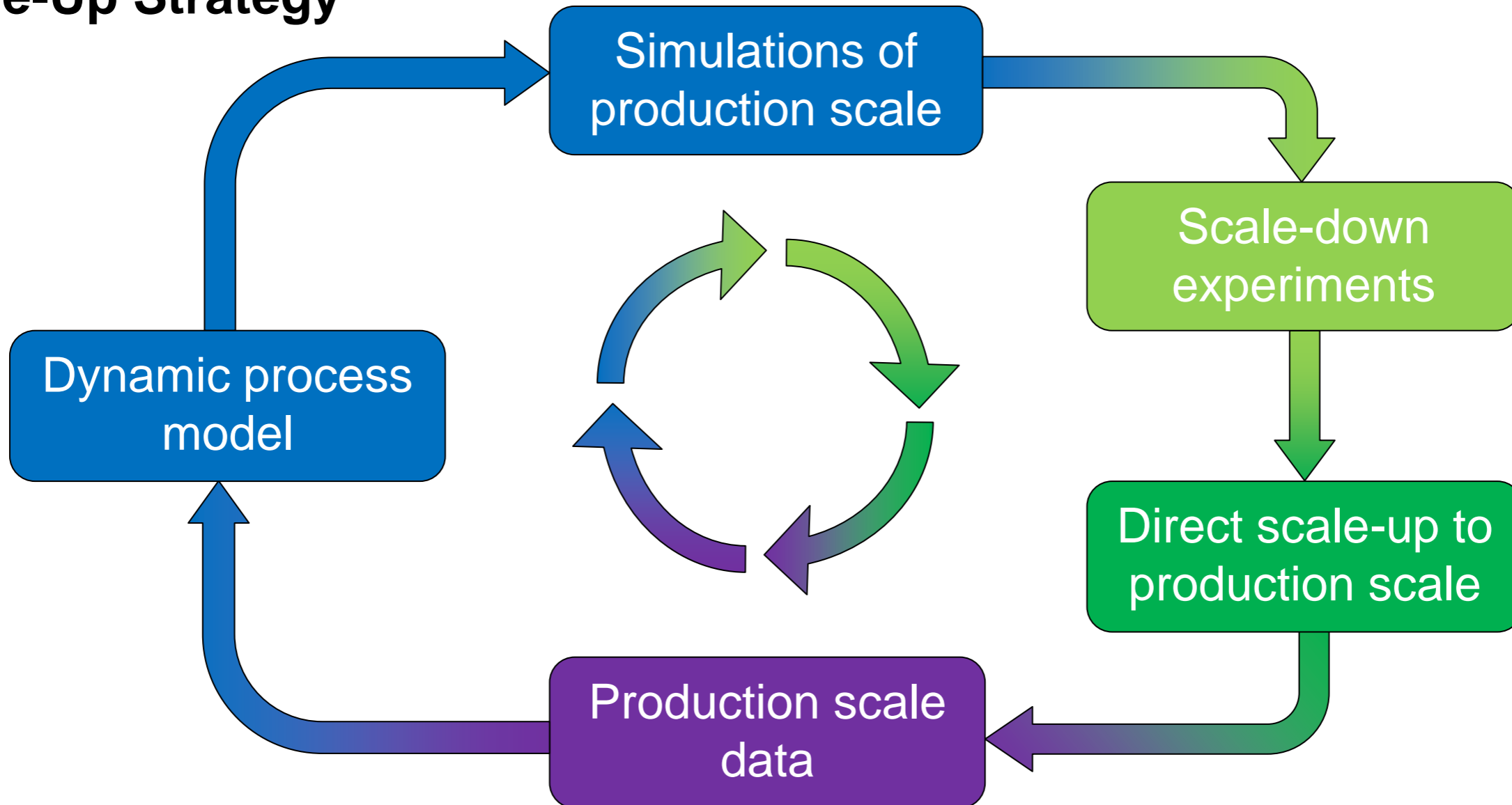

Dynamic process model

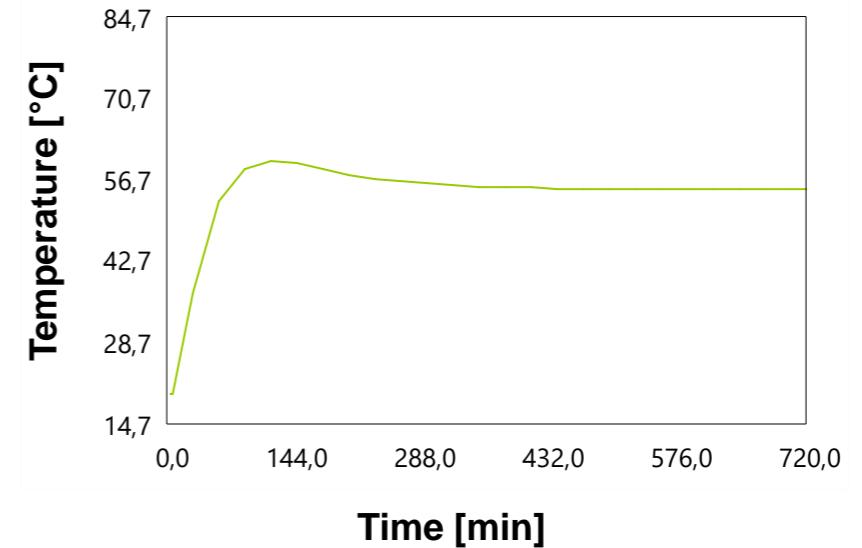
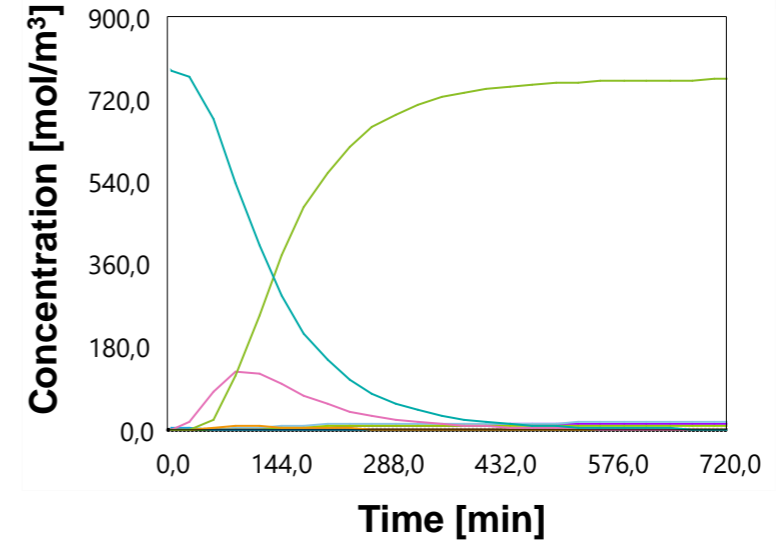
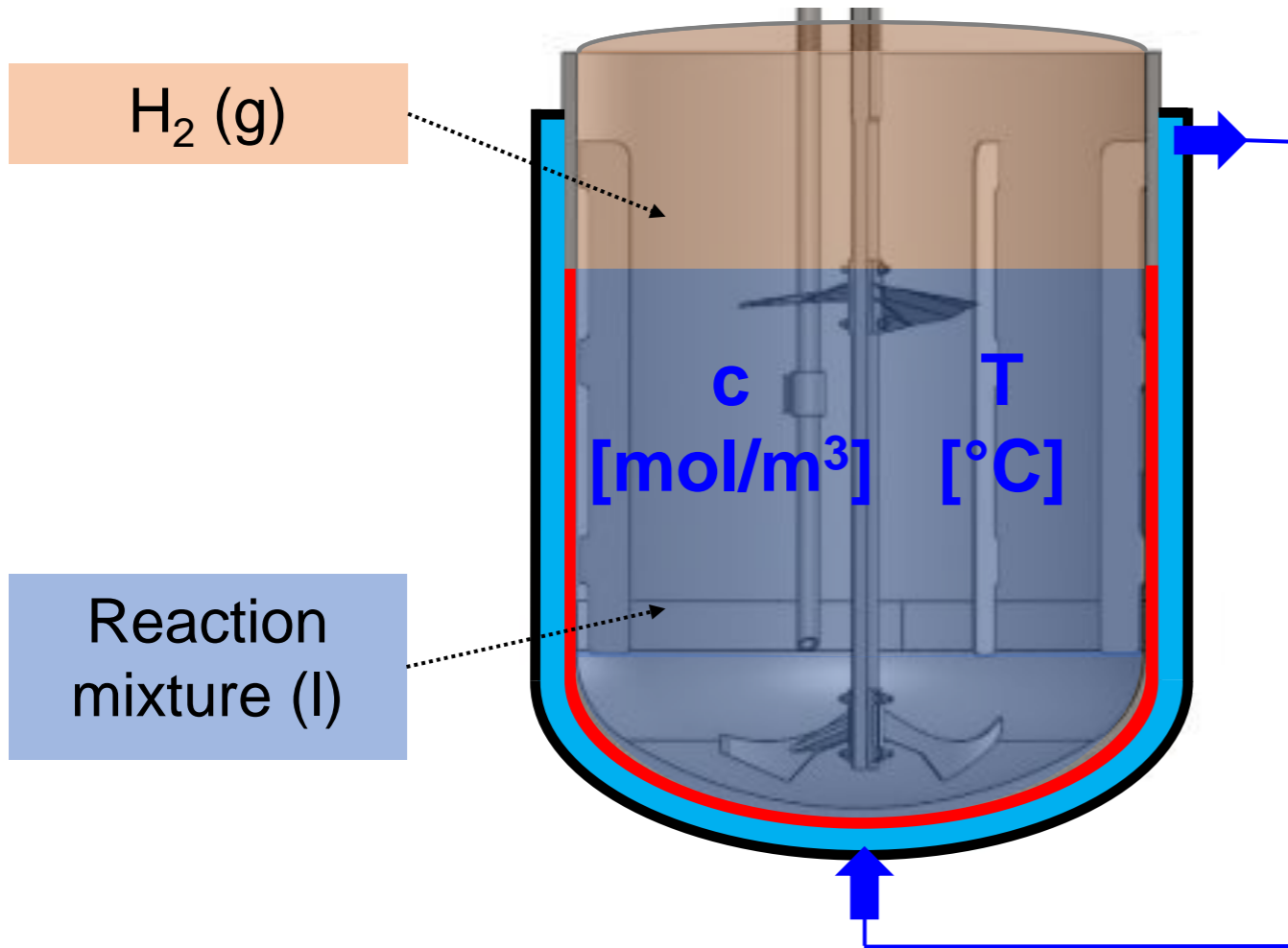

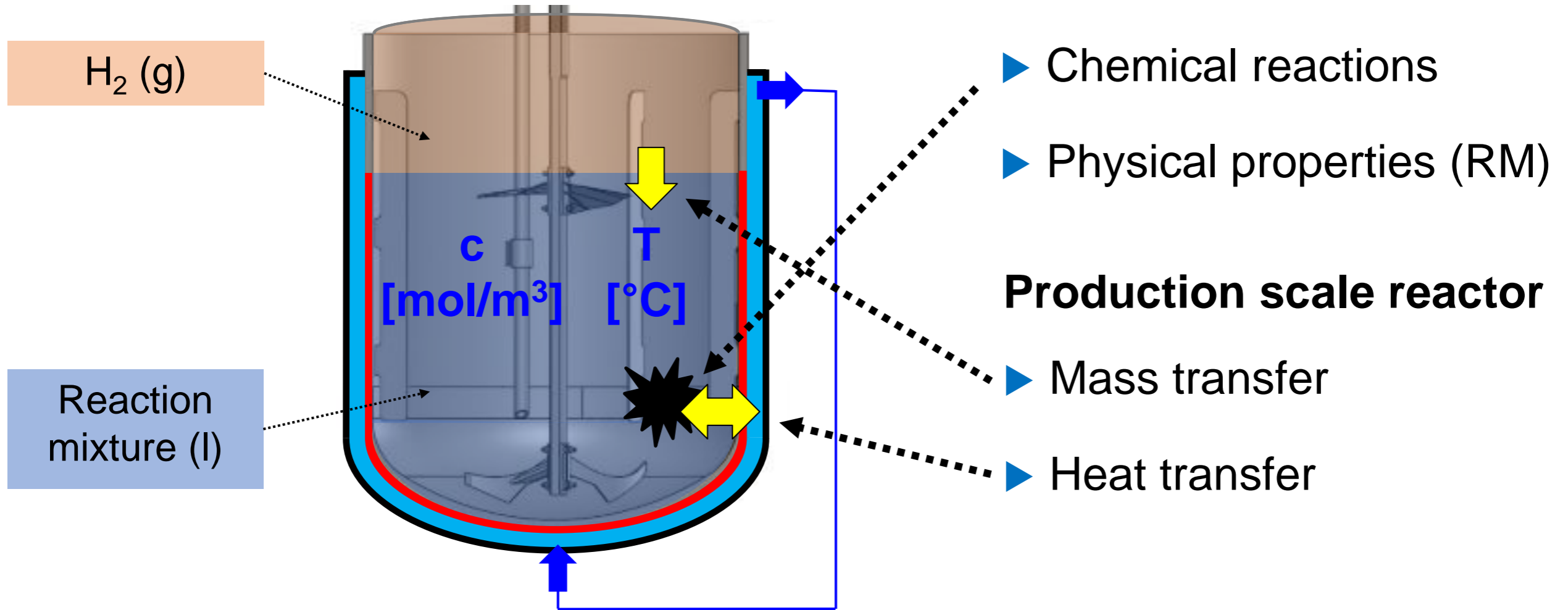

Scale-Up Strategy

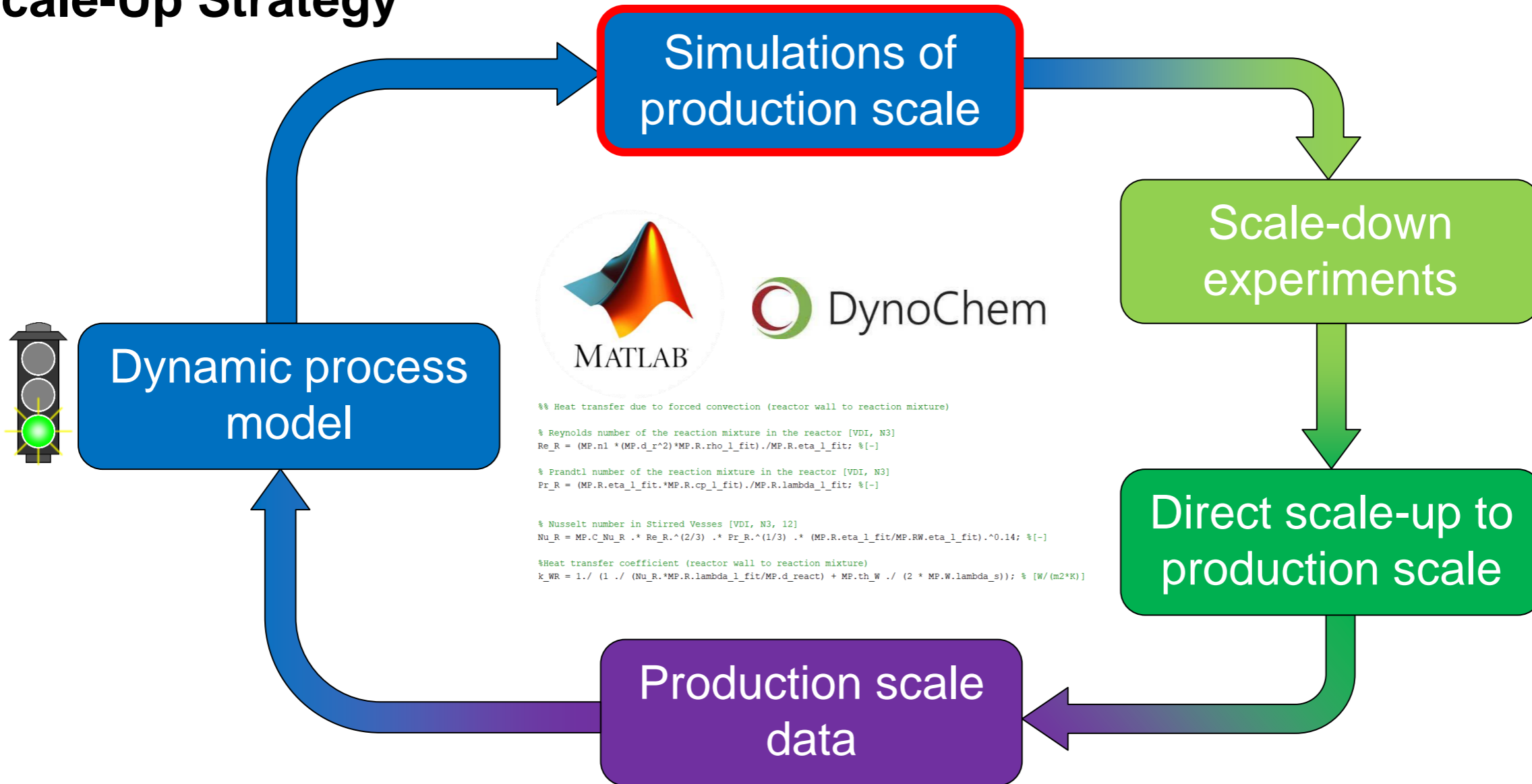

Process parameters

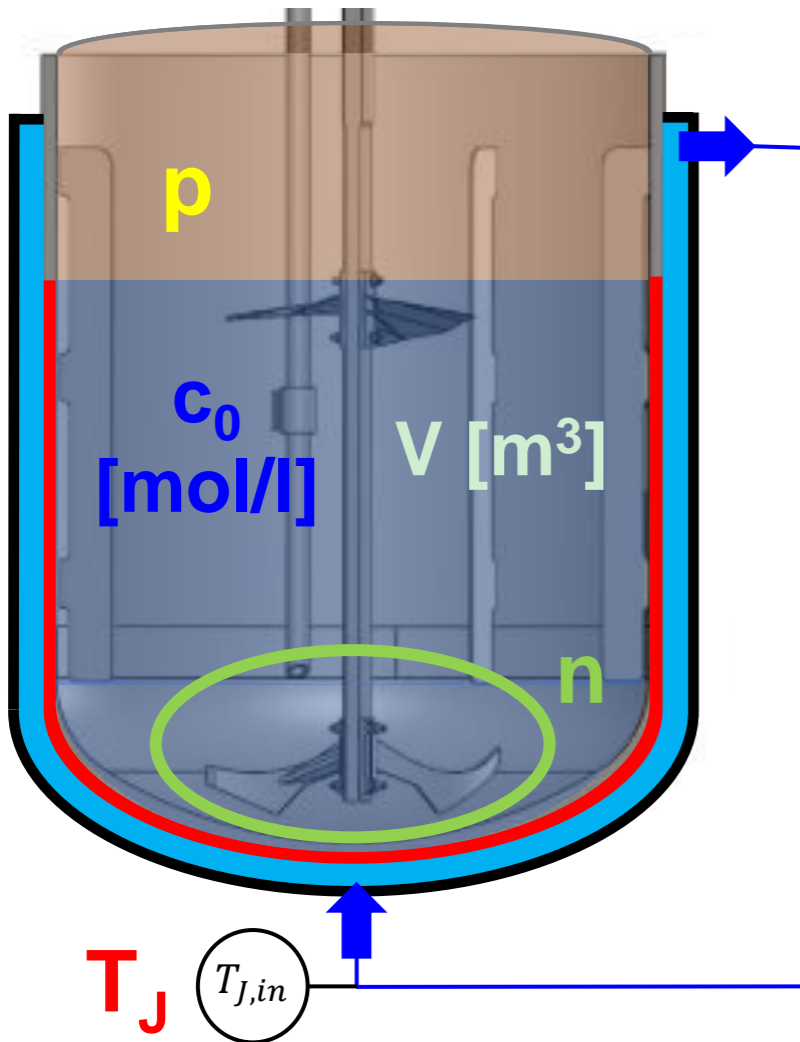

Simulations of
production scale

Process performance

- ▶ Quality (yield, side products, ...)
- ▶ Production capacity

Safety

- ▶ Quantitative risk analysis (focus on severity)

Scale-Up Strategy

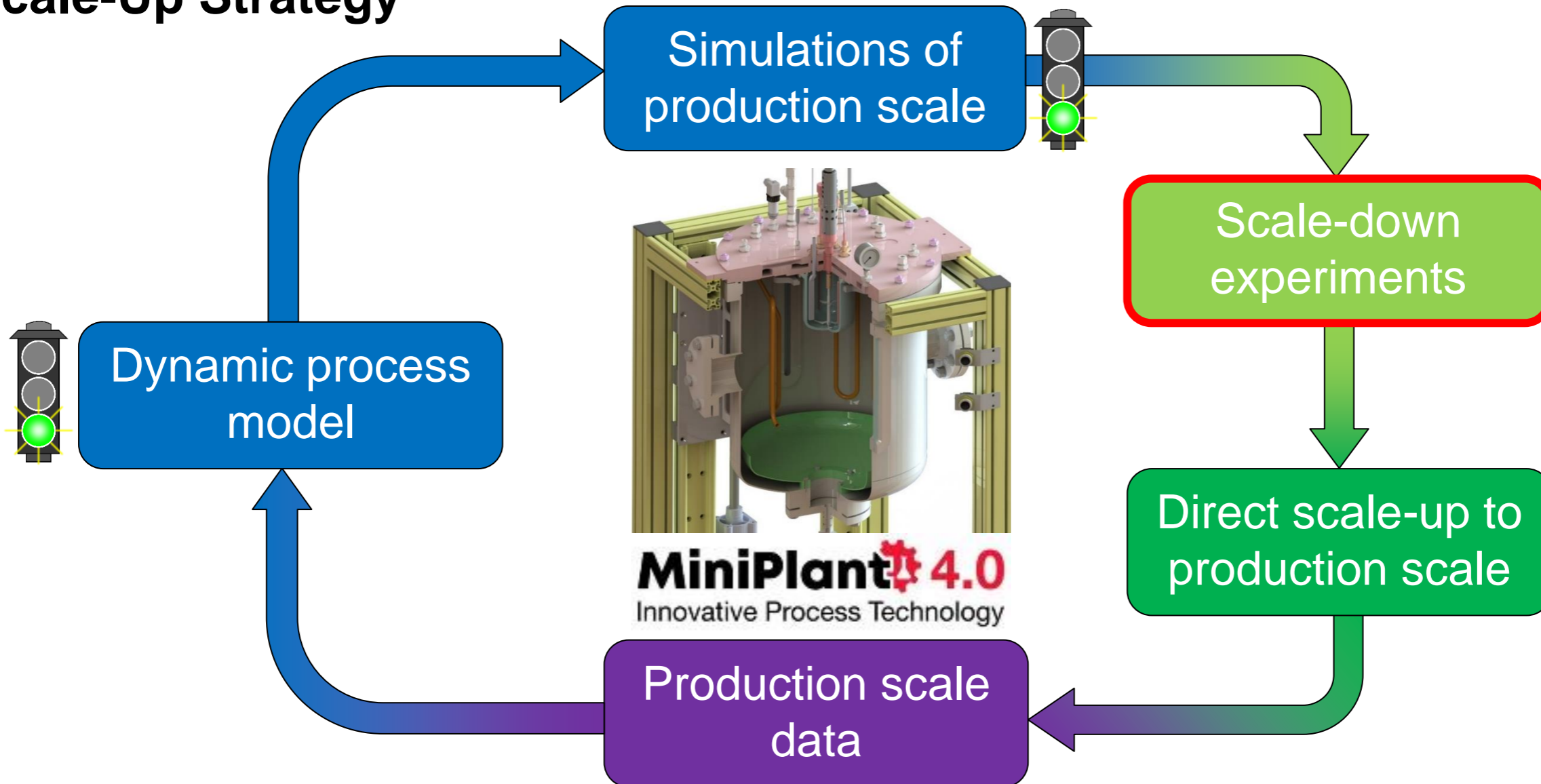

Scale-down
experiments

Miniplant: 1 l

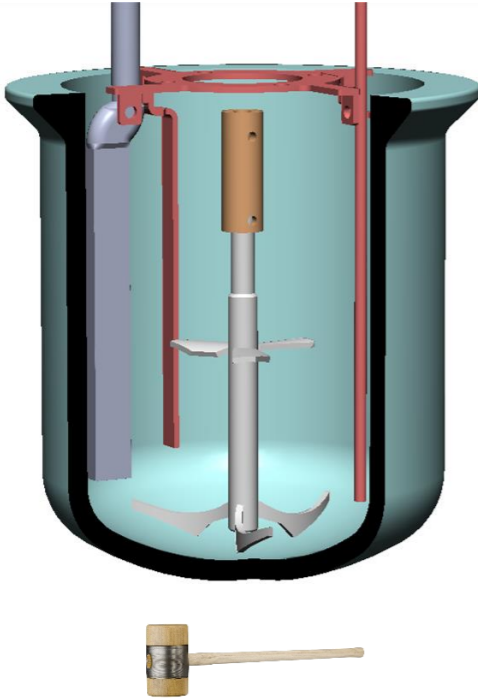

Direct Scale-Up

Production: 4'000 l

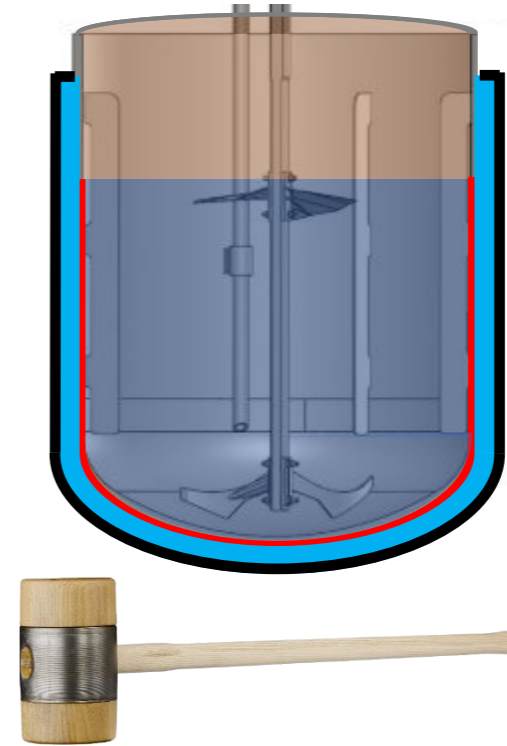

- ▶ **Geometrical** similarity (bottom, stirrer, baffles)
- ▶ Identical **materials** (lab and production)
- ▶ Similar heat transfer area to volume ratio (**Hot / Cold Spots**)

Miniplant

- ▶ Laboratory safety
- ▶ Adiabatic shield

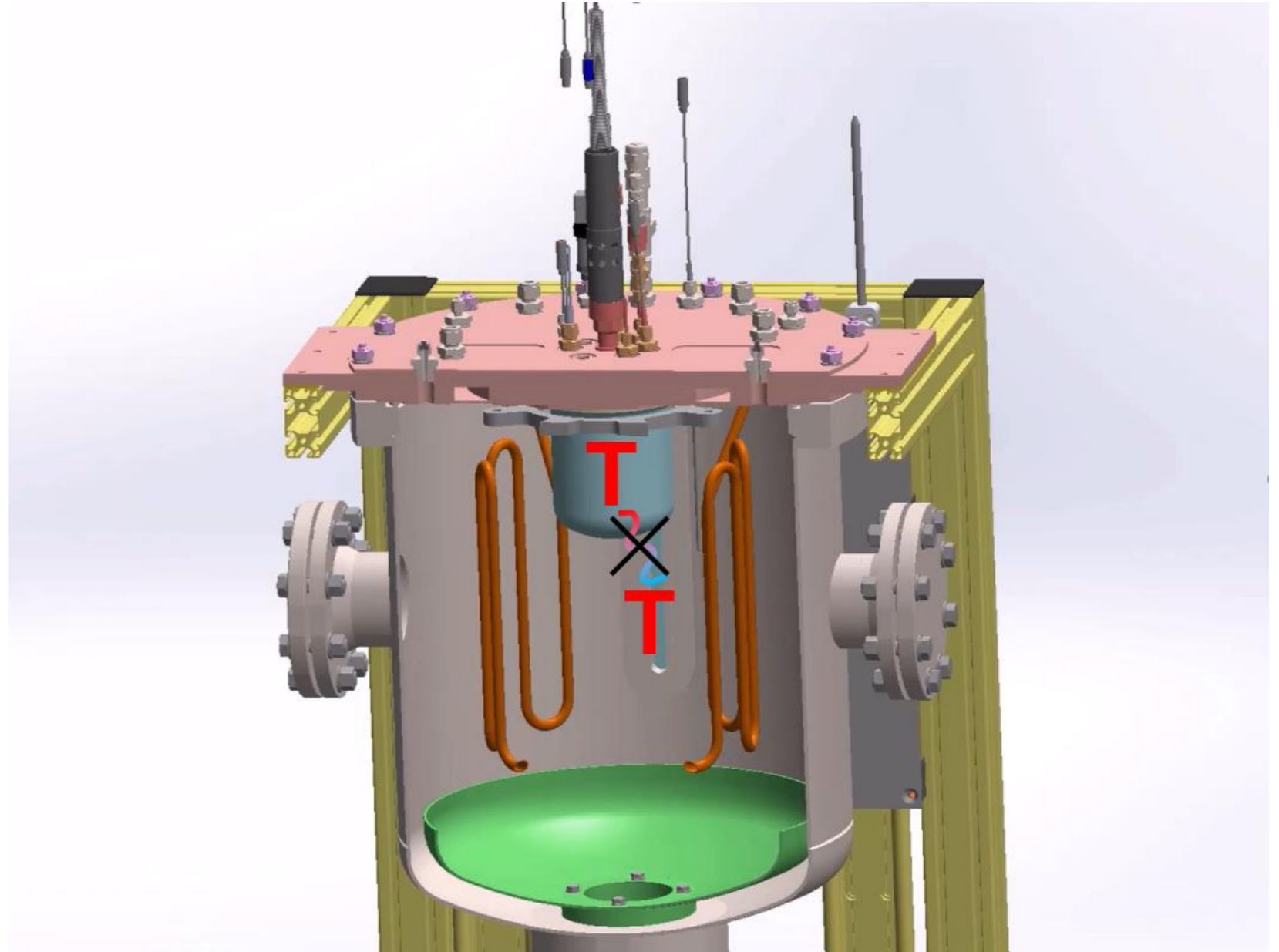

Miniplant

- ▶ Geometry (mass transfer)
- ▶ Heat transfer

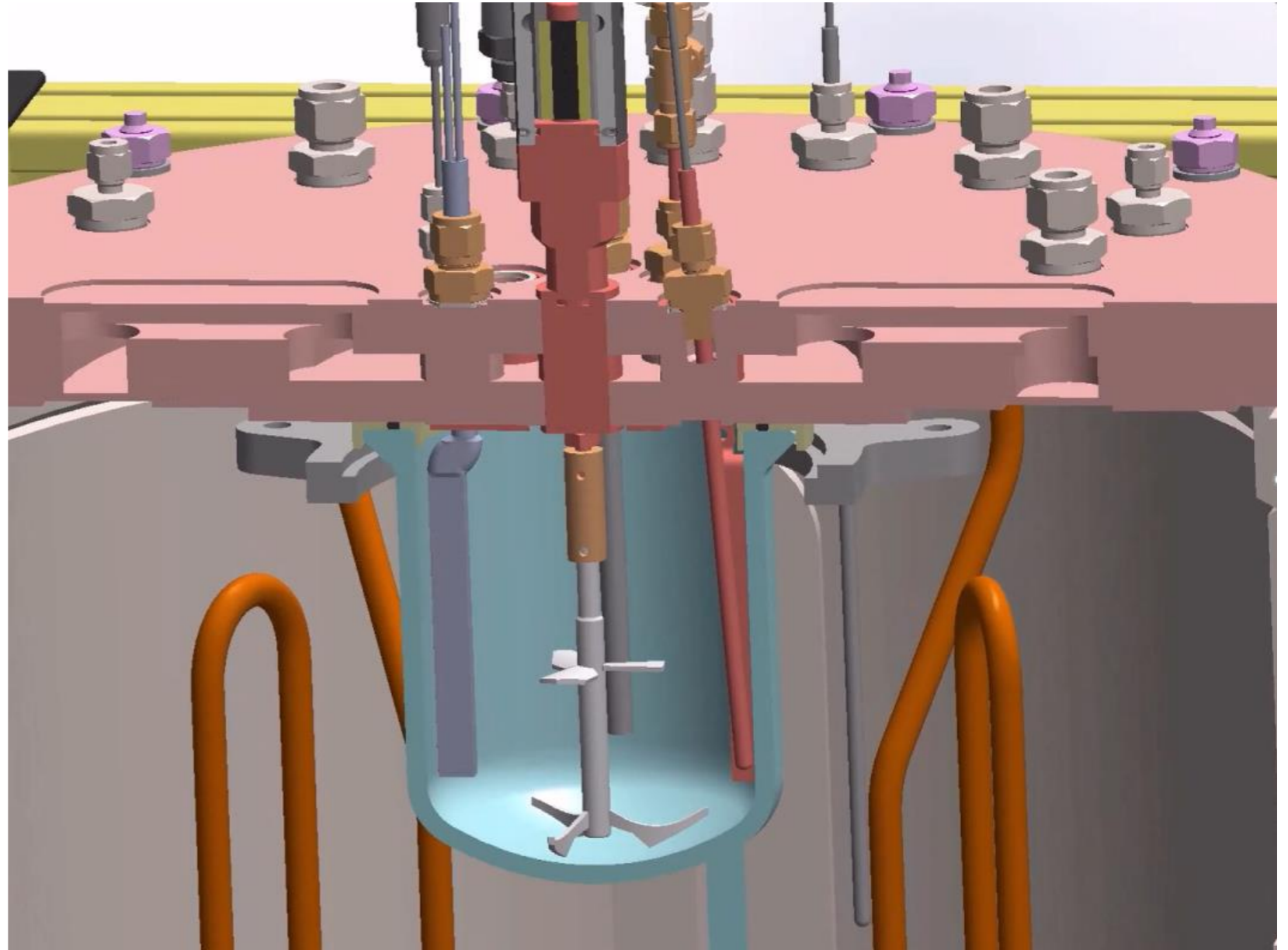

Scale-down experiments

H/C-Finger

- ▶ Computational fluid dynamics

(CFD) n|w Fachhochschule Nordwestschweiz
Hochschule für Technik

- ▶ 3D Printing (316L)

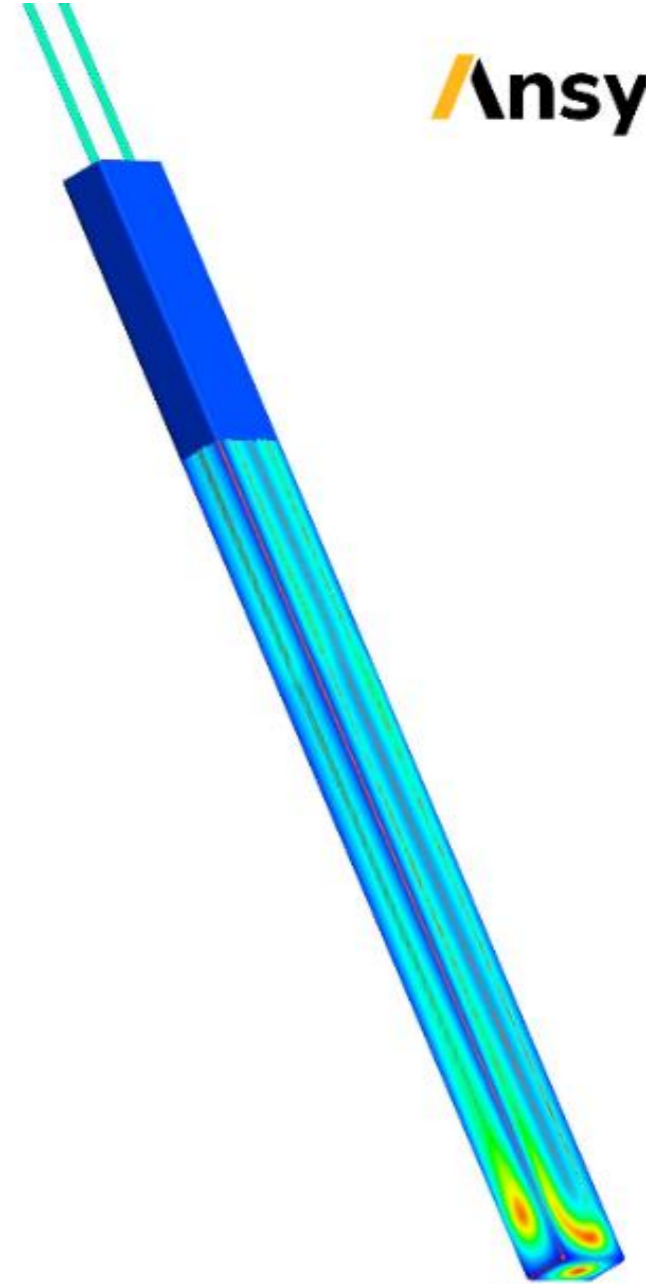
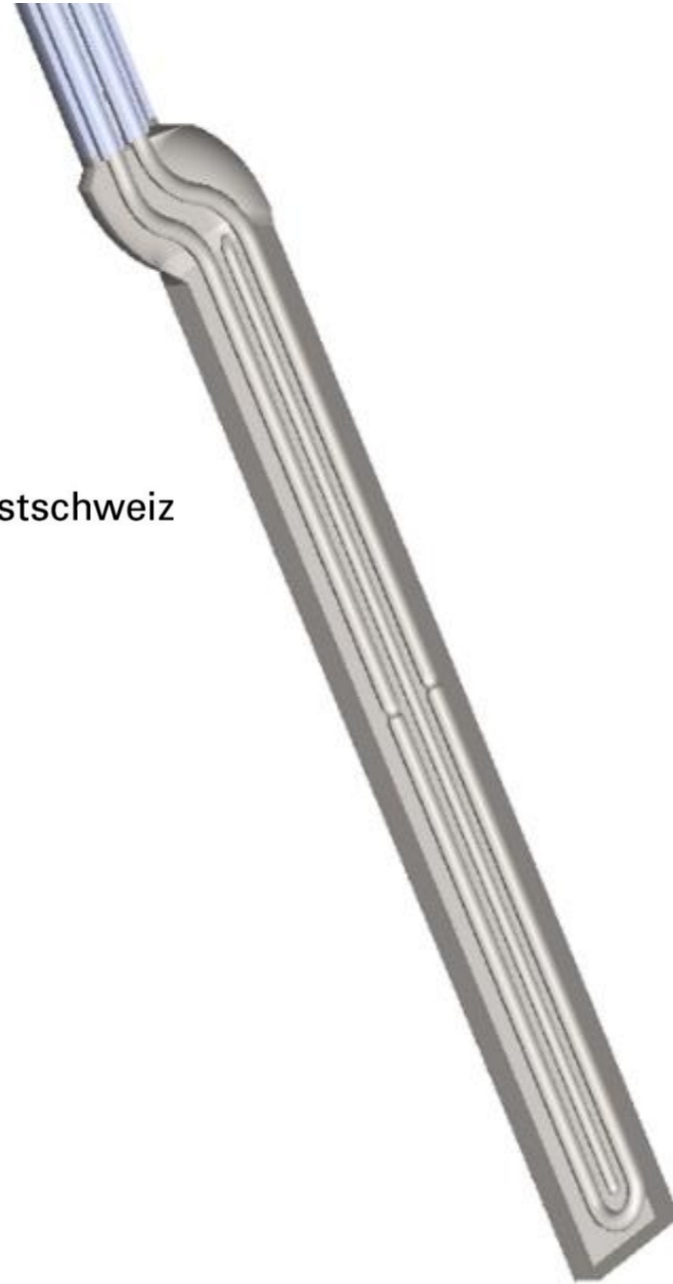

Scale-Up Strategy

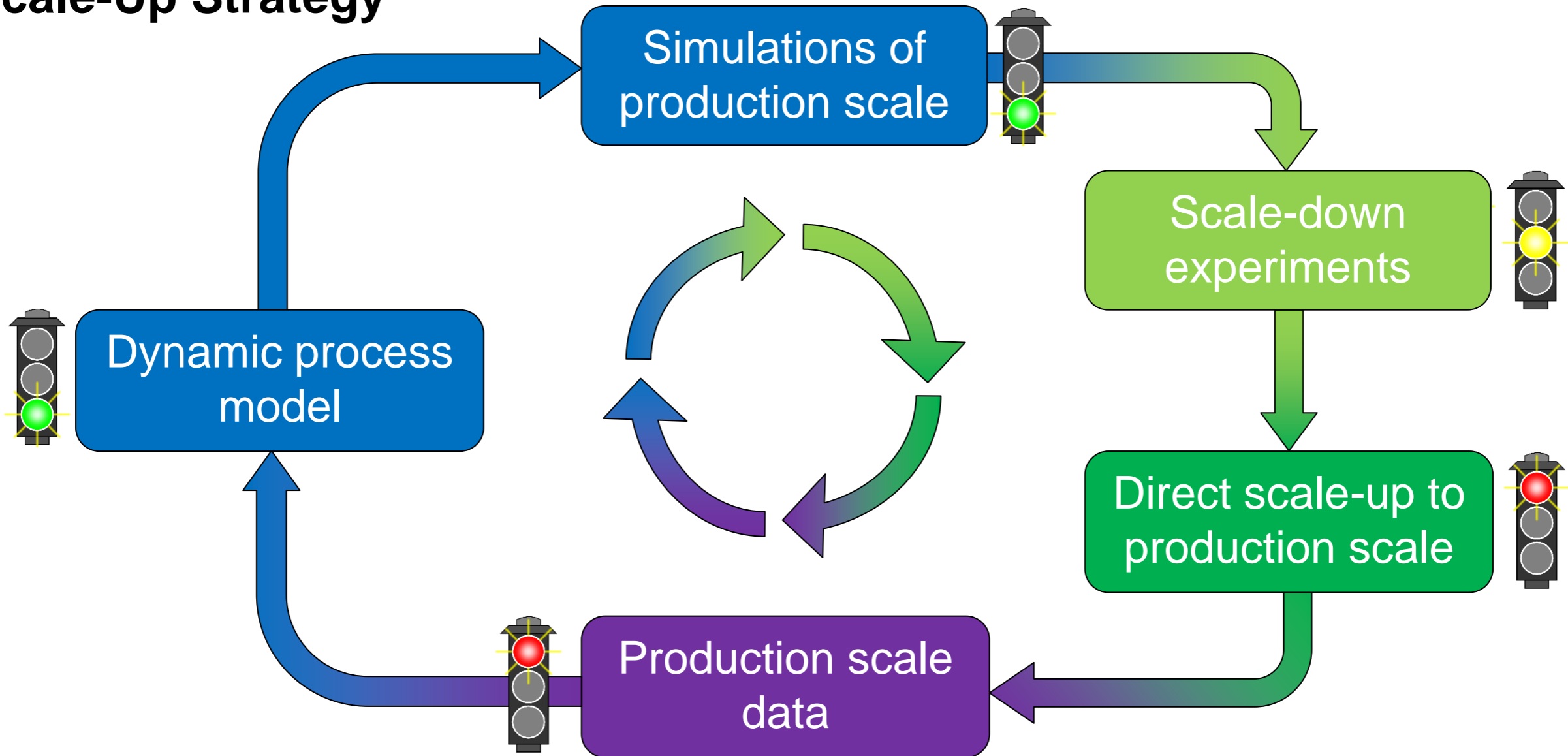

Table of contents

- **Introduction**
A. Zogg
- **Example application: Hydrogenation reactions**
T. Furrer
- **Outlook: Digital Process Lab**
A. Zogg

Outlook: Digital Process Lab

PTC - Muttenz

Miniplant (Scale-Down Reactor)



SPS



Labor-Leit-System

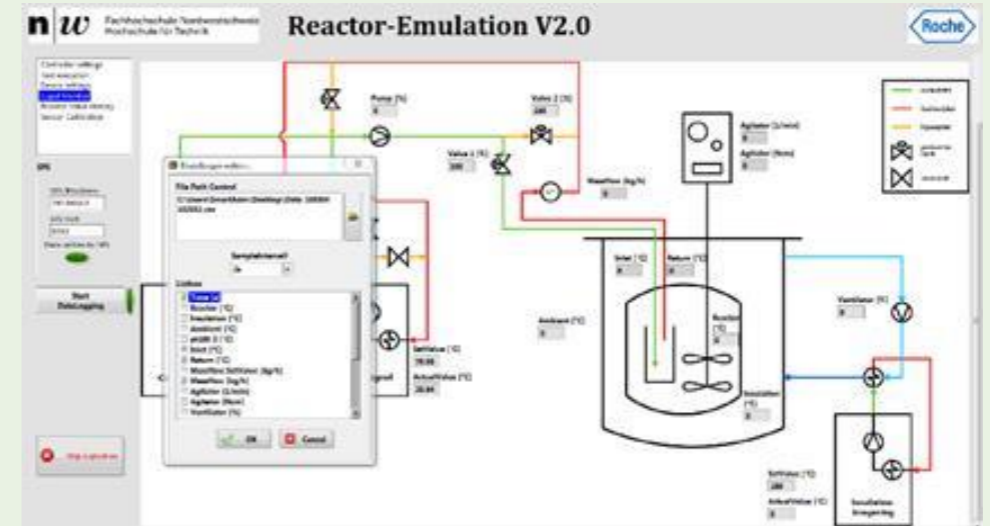

J erome Blum, Karl-Heinz Langendorf, Prof. Dr. David Zogg.

Outlook: Digital Process Lab

PTC - Muttenz

Miniplant (Scale-Down Reactor)



SPS

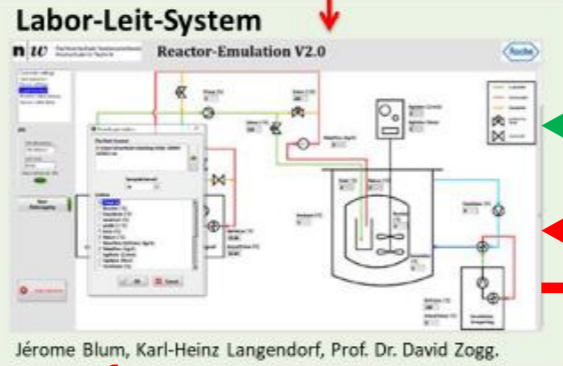

Batch Record
Recorded Data
Sampling Tags

Lab
procedure

Cobalt

Prof. Dr. Christian
Kronseder
(FHNW-HLS)

MPC (Model Predictive Control)

Engineering
Model

Dynamic process
model

Prof. Dr. David Zogg (FHNW-HT)



Thank you!

Siegfried

- ▶ Michael K. Levis
- ▶ Bernhard Berger
- ▶ Martina Hediger

MiniPlant 4.0
Innovative Process Technology

- ▶ Jürg Thut
- ▶ Andreas Stubbe
- ▶ Hans-Peter Zbinden
- ▶ Benedikt Müller
- ▶ Jonas Asprion

n|w

Muttenz (HLS):

- ▶ Christoph Hasler
- ▶ Ronny Hardegger
- ▶ Gonzalo Álvarez
- ▶ Christelle Jablonski
- ▶ This Zahnd
- ▶ Benedikt Brönnimann
- ▶ Christian D. Maier
- ▶ Pavel Dagorov
- ▶ André Büttler
- ▶ Timm Hettich
- ▶ Christian Berchtold
- ▶ Götz Schlotterbeck
- ▶ Sebastian Wendeborn

n|w

Windisch (HT):

- ▶ Daniel Weiss
- ▶ Weiqun Geng
- ▶ Jana Hoffmann
- ▶ David Zogg
- ▶ Steffen Thierer

 **FORSCHUNGSFONDS**
AARGAU

- ▶ Marco Romanelli
- ▶ Markus Ehrat