

Scaling Down the Heat Transfer in Multipurpose Plants

Prof. Dr. Andreas Zogg

Praxis Zirkel Life Sciences

26.06.2024

andreas.zogg@fhnw.ch

<https://www.fhnw.ch/plattformen/miniplant40/projects/>

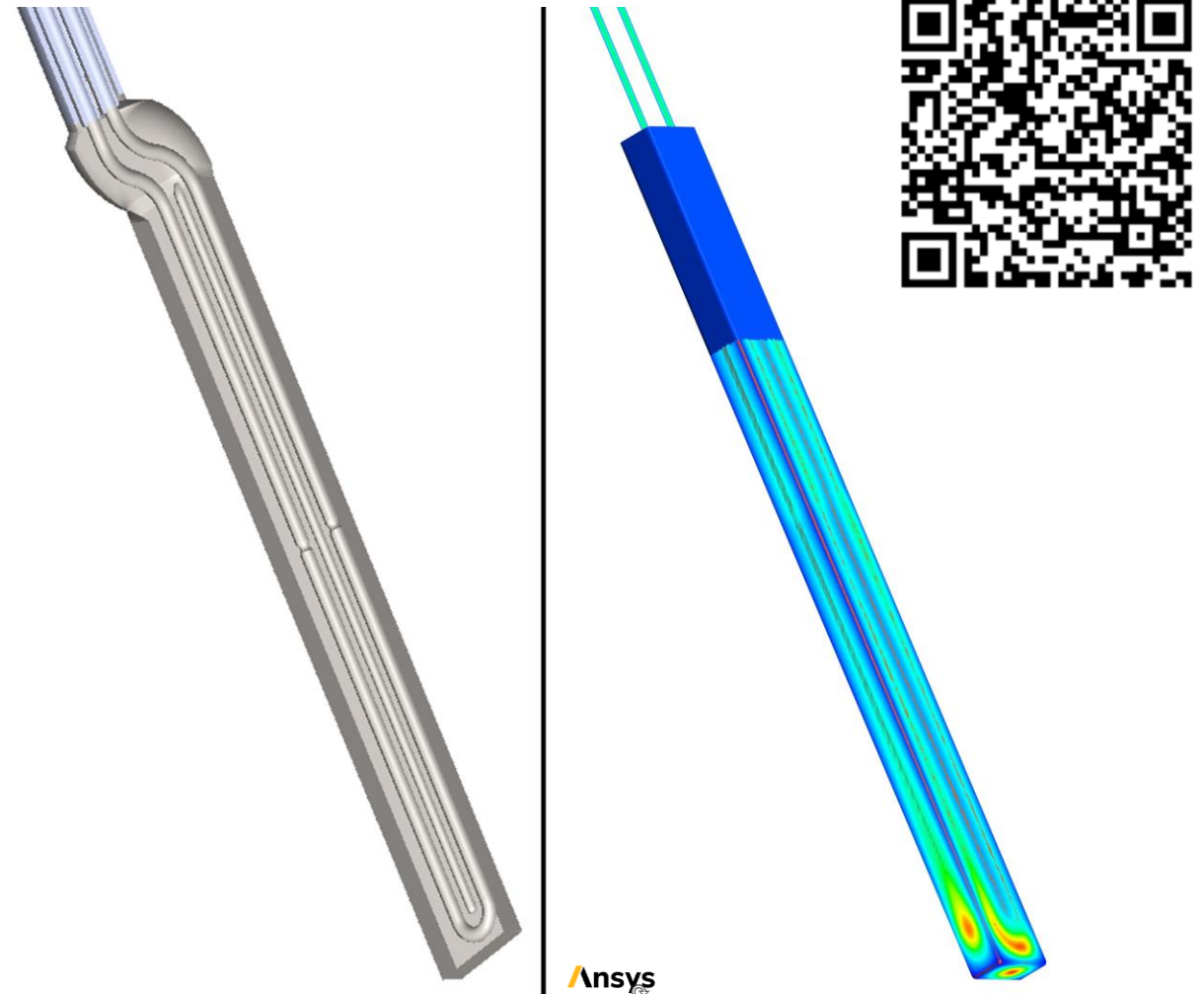

Einleitung

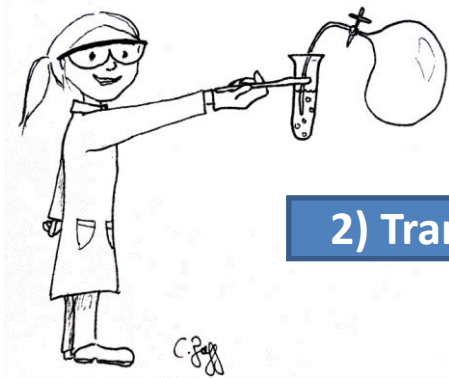

2) Transfer

Laboratory Process

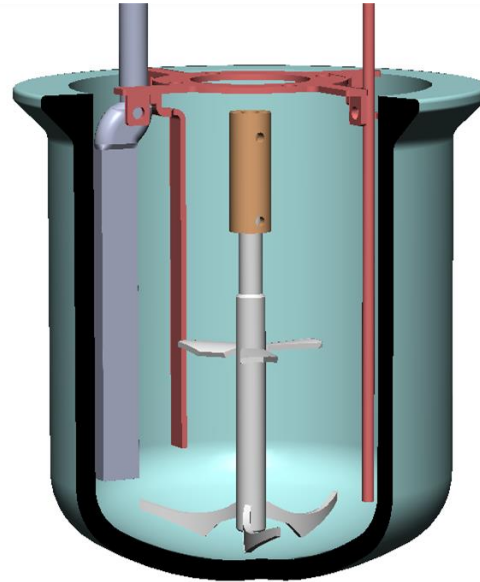

Scale-Down-Reactor

1) Scale-Down

3) Scale-Up



Production Process

Inhalt

1. Einleitung

- Stand der Technik beim Scale-Up
- Vision für den zukünftigen Scale-Up – Herausforderung Wärmeübertragung

2. Zielsetzung des Projekts

3. Konkrete Aufgabenstellung: Scale-Down eines 4 m³ Hydrierautoklaven

4. Workflow:

- Design des Heiz/Kühlfingers
- Herstellung und Inbetriebnahme des Heiz/Kühlfingers
- Qualifizierung des Heiz/Kühlfingers im stationären Zustand

5. Anwendungsbeispiel: Hydrierung

6. Outlook

Stand der Technik beim Scale-Up

Laboratory: 0.1 ... 1 l

Pilot: 10 ... 100 l

Production: 1'000 ... 10'000 l

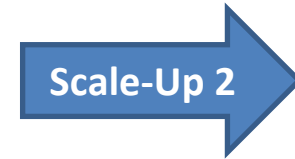
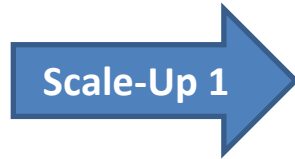

$$r = (\sqrt{\pi})^{??}$$

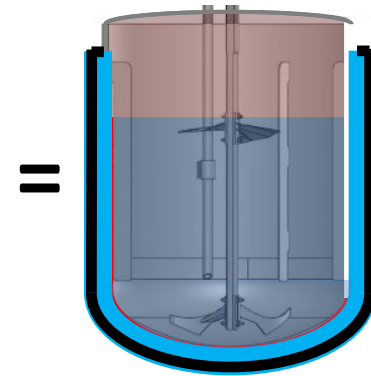

Vision für den zukünftigen Scale-Up

Scale-Down-Reactor
1 ... 10 l

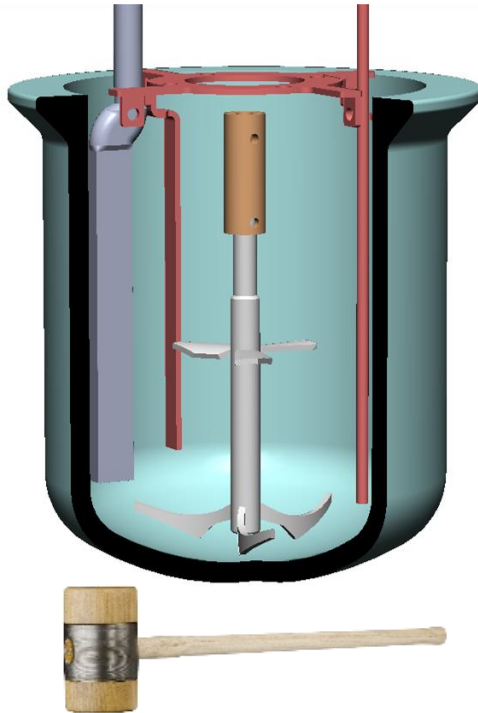

Direct Scale-Up

Production
1'000 ... 10'000 l

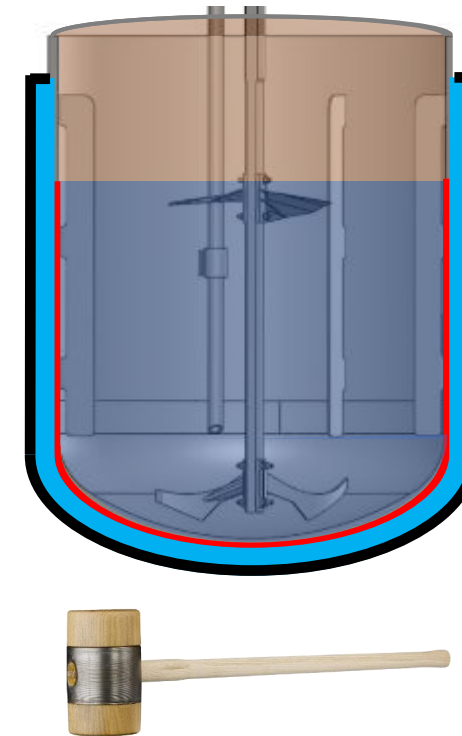

► Herausforderung: Scale-Up der Wärmeübertragung!

Stand der Technik der Wärmeübertragung beim Scale-Up

Standard Lab-Reactor: 1 l

heat exchange via glass jacket

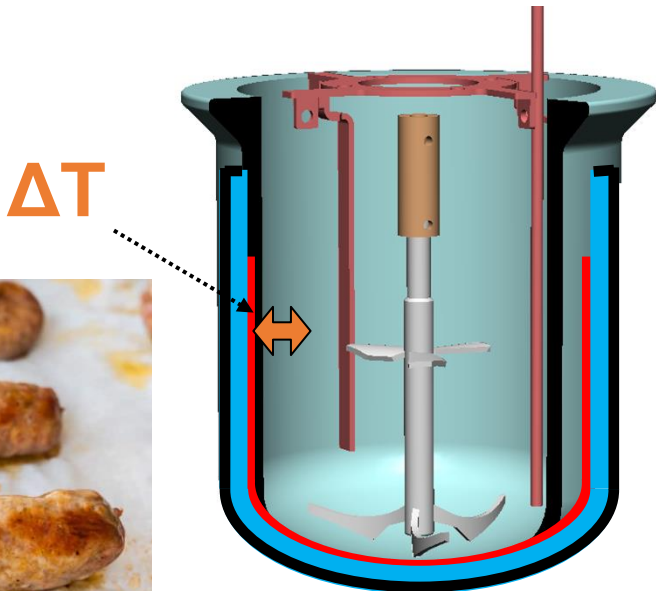

Direct Scale-Up ?

Production: 4'000 l

heat exchange via jacket

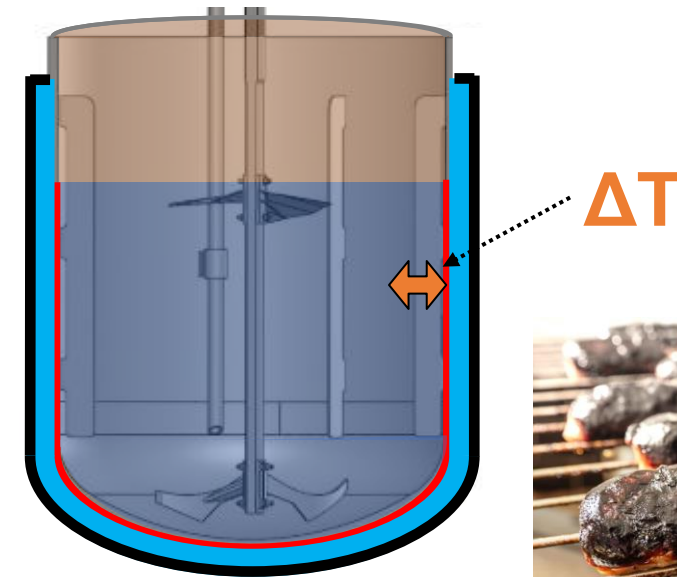

$\Delta T \approx 15 \times$ grösser
als im Labor !

Neuer Ansatz für die Wärmeübertragung beim Scale-Up

Scale-Down-Reactor: 1 l
Heat exchange via H/C-Finger

Production: 4'000 l
heat exchange via jacket

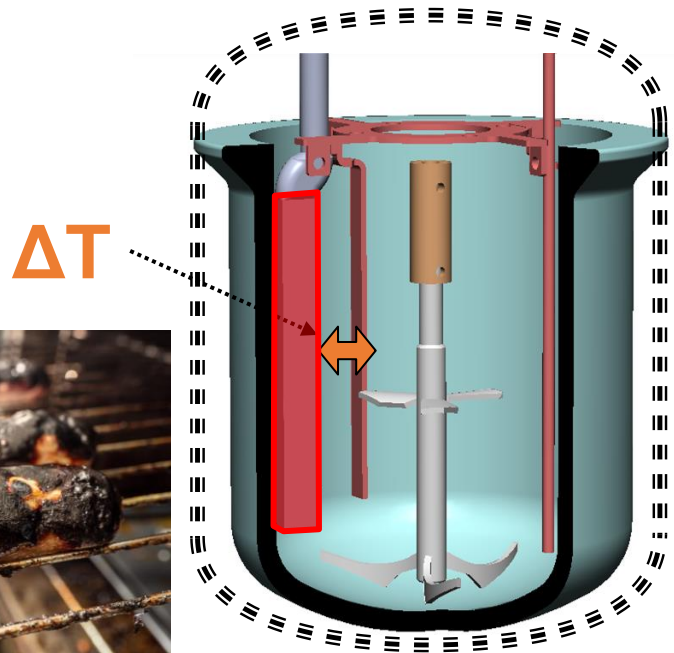

Adiabatic Shield

Direct Scale-Up

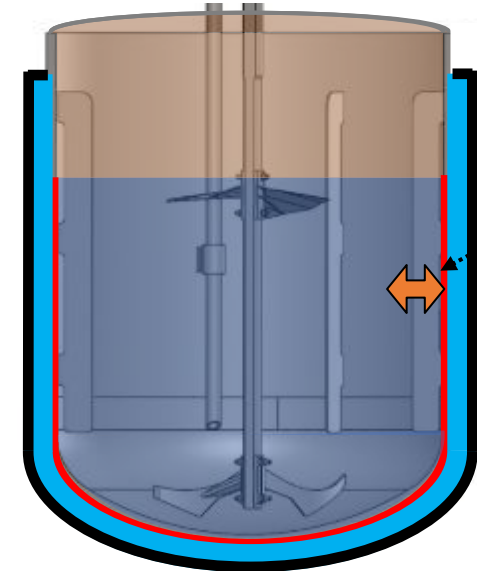

ΔT bleibt beim Scale-Up konstant

Zielsetzung des Projekts

The H/C-Finger should be designed to **simulate the impact of the wall temperature** as well as the **wall material** on the investigated process already in lab scale.

Effects such as ...

- ... **by-product formation** due to a hot reactor wall
- ... the formation of different **polymorphs** during crystallization due to a cold reactor wall
- ... the impact of **corrosion** on a catalytic process or product quality

... can now be investigated prior to the scale-up to production scale.

→ The novel Scale-Down-Reactor thus **shortens the development time and minimizes the needs for intermediate process trials in pilot scale.**

Aufgabenstellung: Scale-Down des Wärmetransports eines Hydrierautoklaven (4 m³ -> 1 Liter)

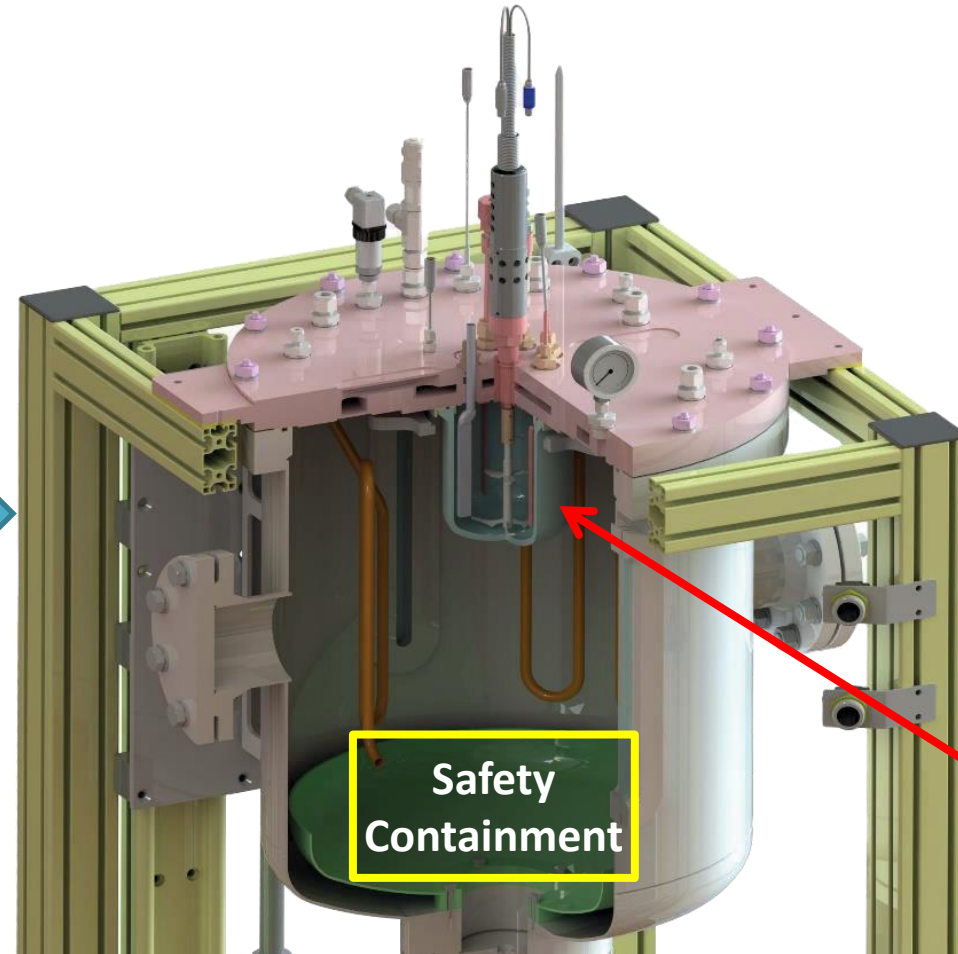
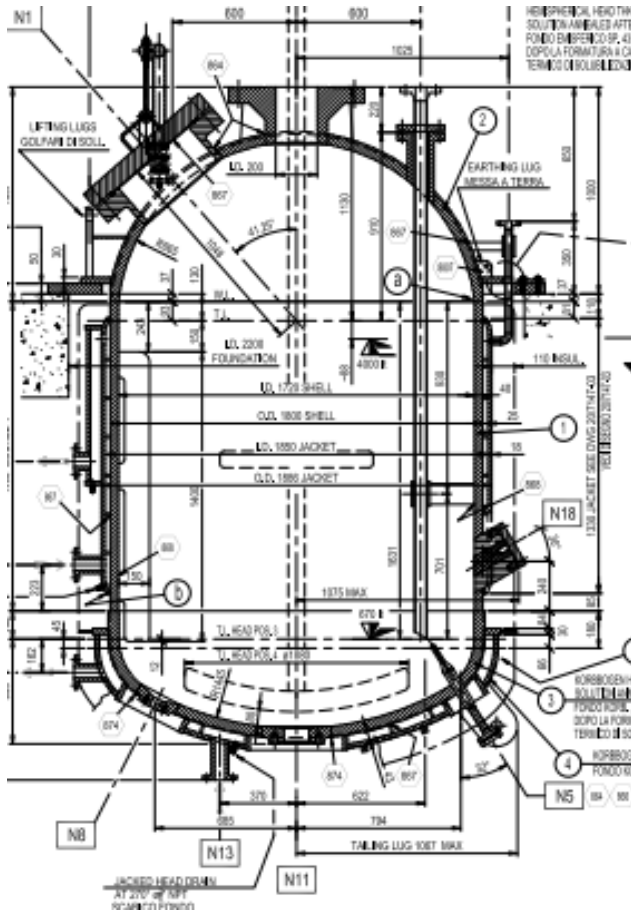

Heating/
Cooling
Finger

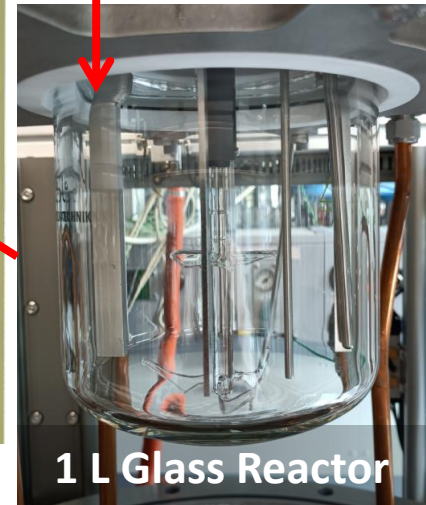

1 L Glass Reactor

Aufgabenstellung: Scale-Down des Wärmetransports eines Hydrierautoklaven ($4 \text{ m}^3 \rightarrow 1 \text{ Liter}$)

Conditions for the design of a Heating/Cooling-Finger:

- Similar **geometry** to a baffle of the production-scale reactor.
- Similar **volume to heat transfer area** ratio as the production-scale reactor.
- Similar **overall heat transfer coefficient** as the production-scale reactor.
- Similar **construction material** as the production-scale reactor wall (904L).

Workflow: Design of the Heating / Cooling Finger

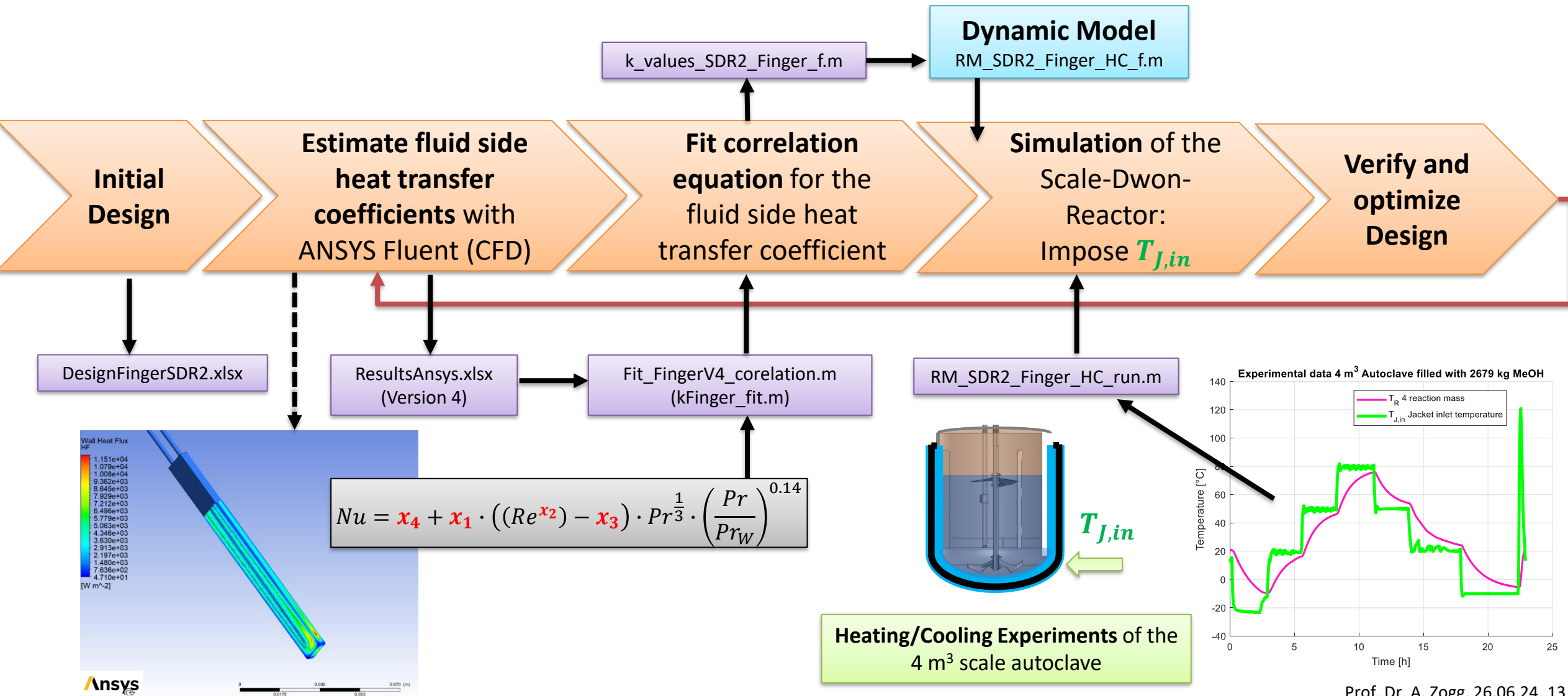

Workflow: Design of the Heating / Cooling Finger

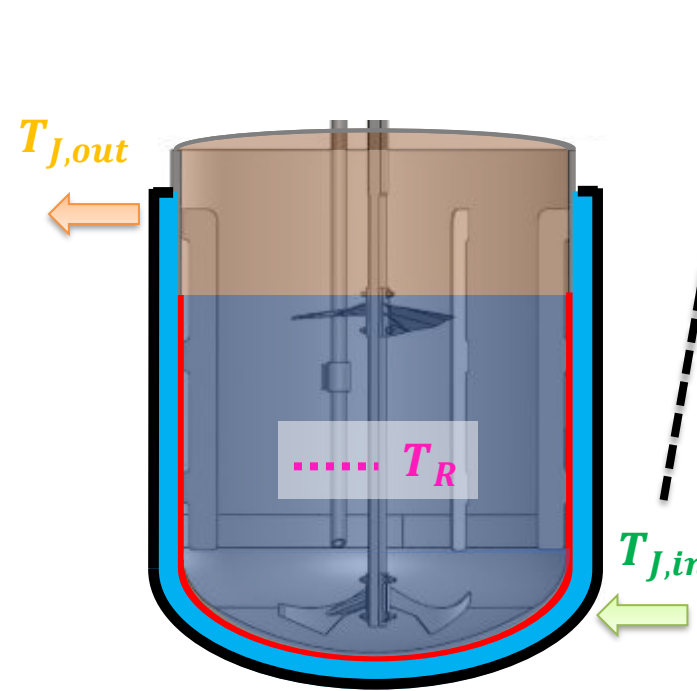
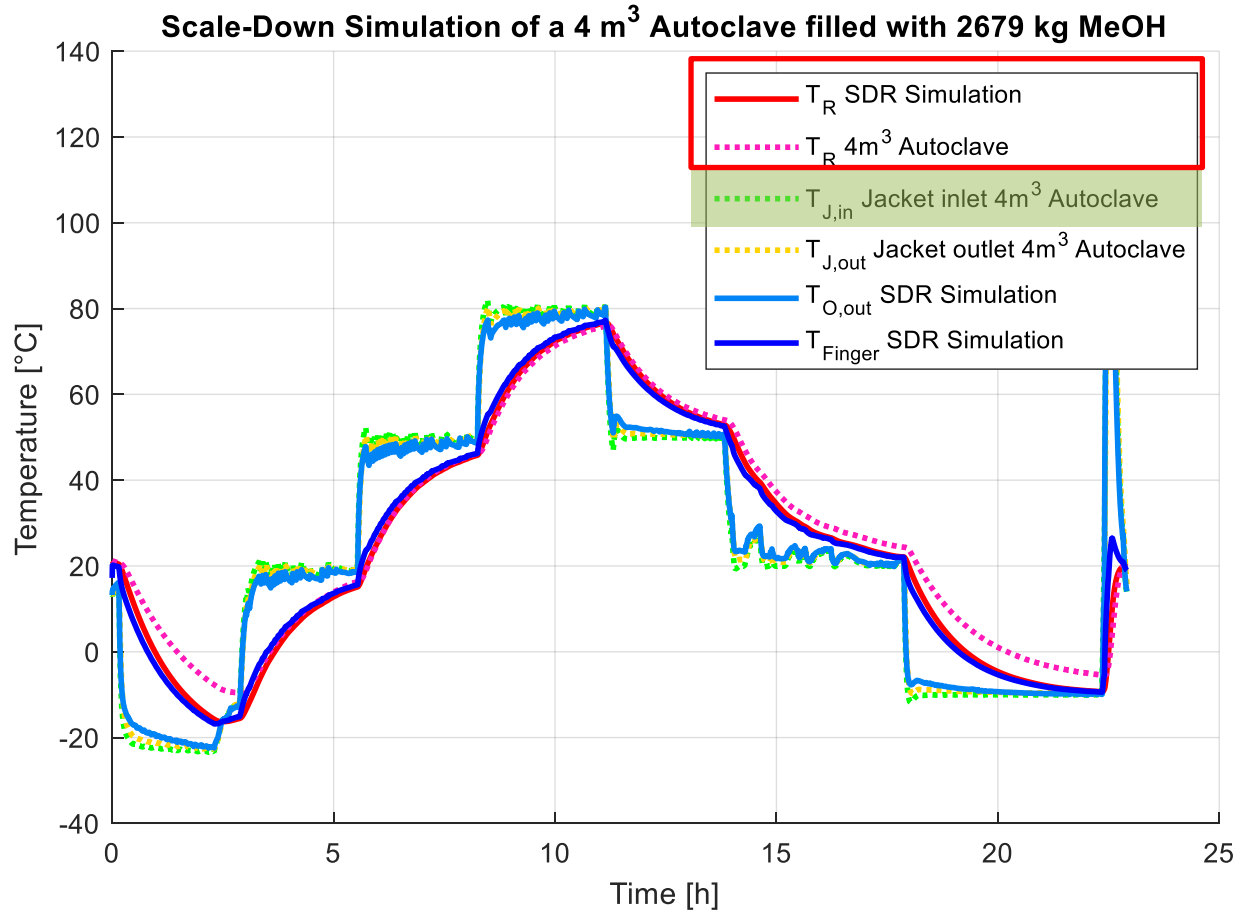

Messdaten aus dem
4 m³ Hydrierautoklaven

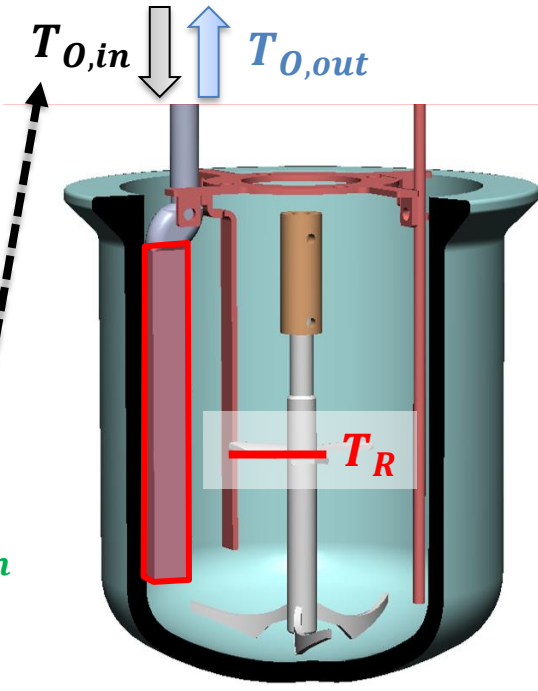

Simulation des Scale-
Down-Reaktors

Dynamic Model
RM_SDR2_Finger_HC_f.m

RM_SDR2_Finger_HC_run.m

Workflow: Manufacturing and Implementation of the Heating/Cooling Finger

3D
Printing

Assembly

Temperature Sensors for
reaction calorimetry

Implementation

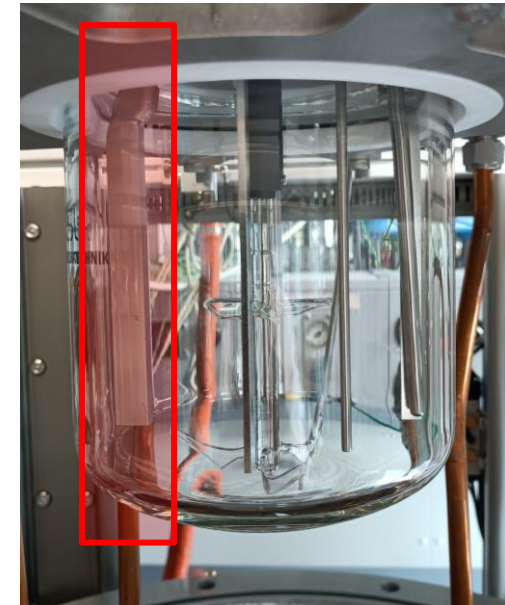
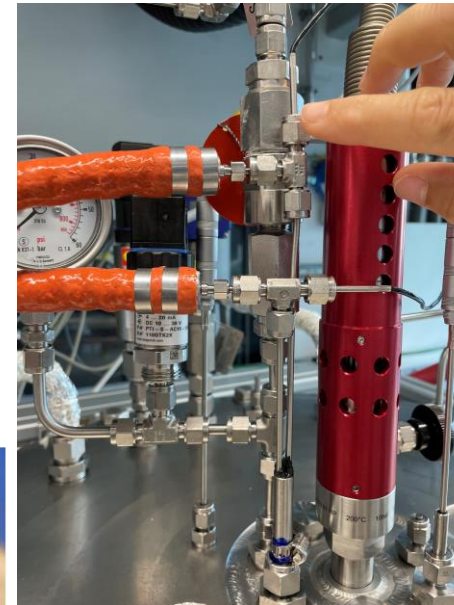
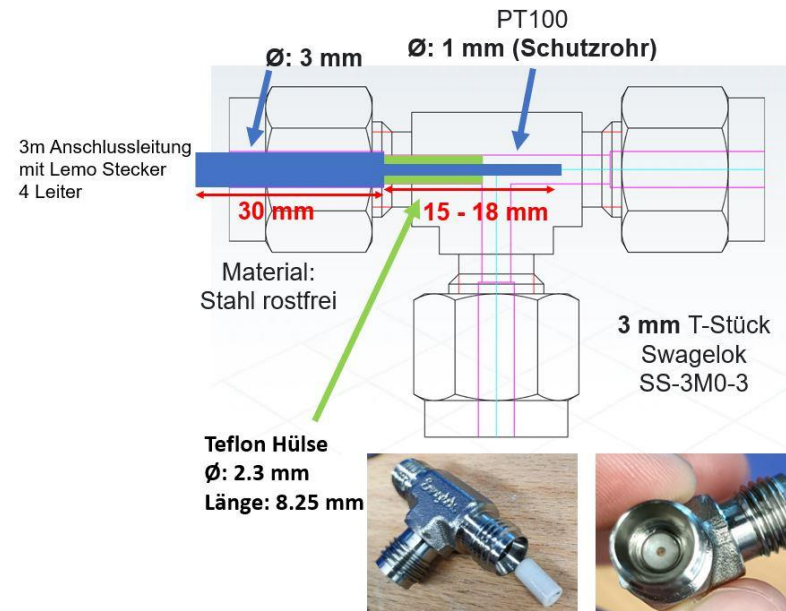
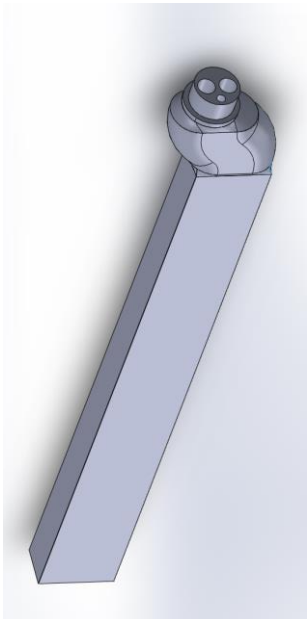

Workflow: Qualification of the H/C-Finger at steady state

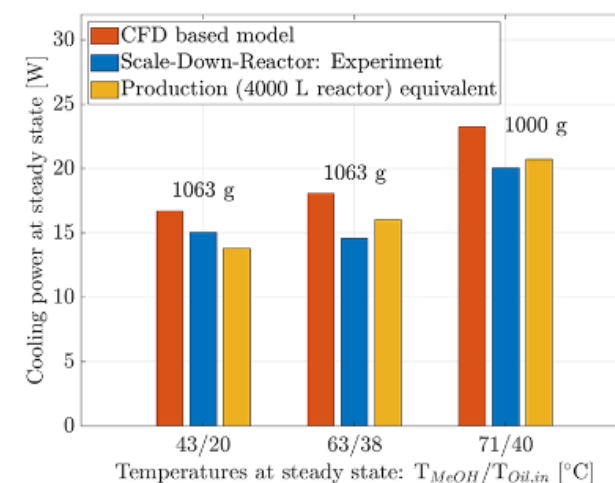
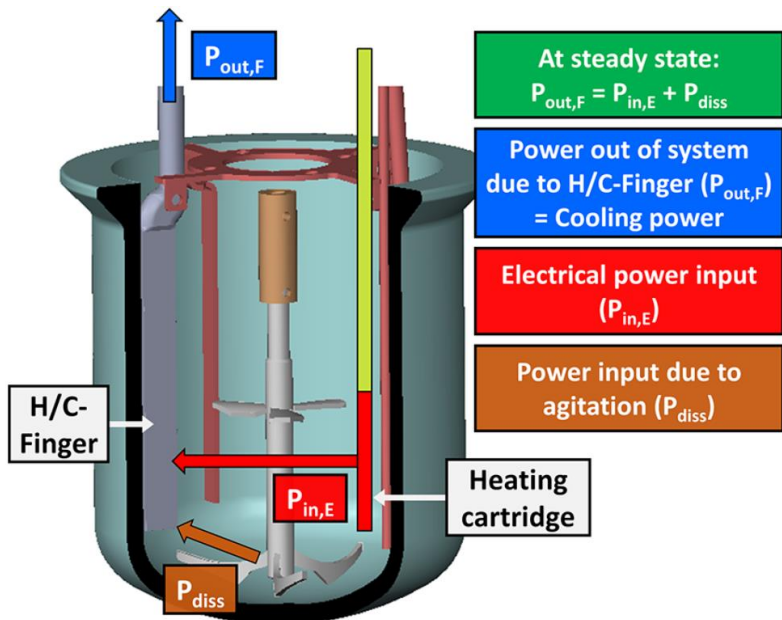
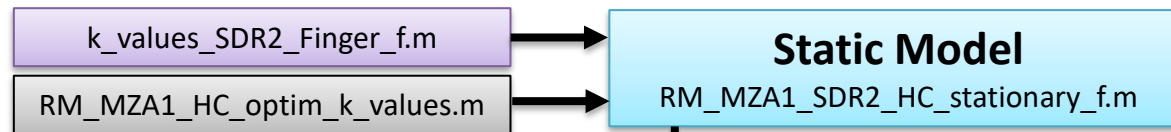

Workflow: Qualification of the H/C-Finger at steady state

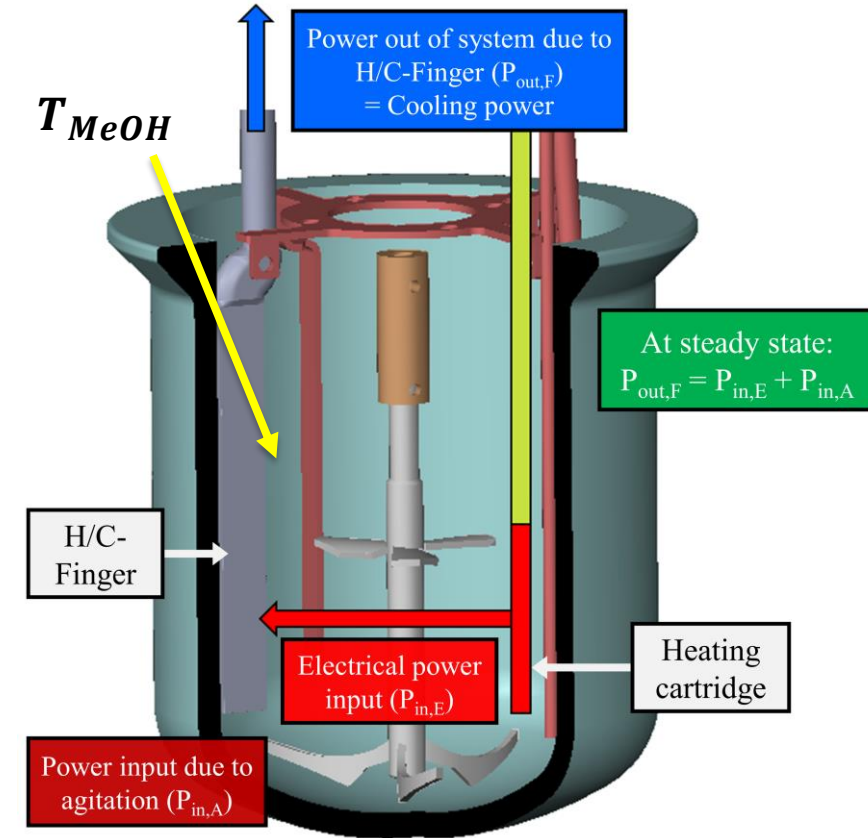
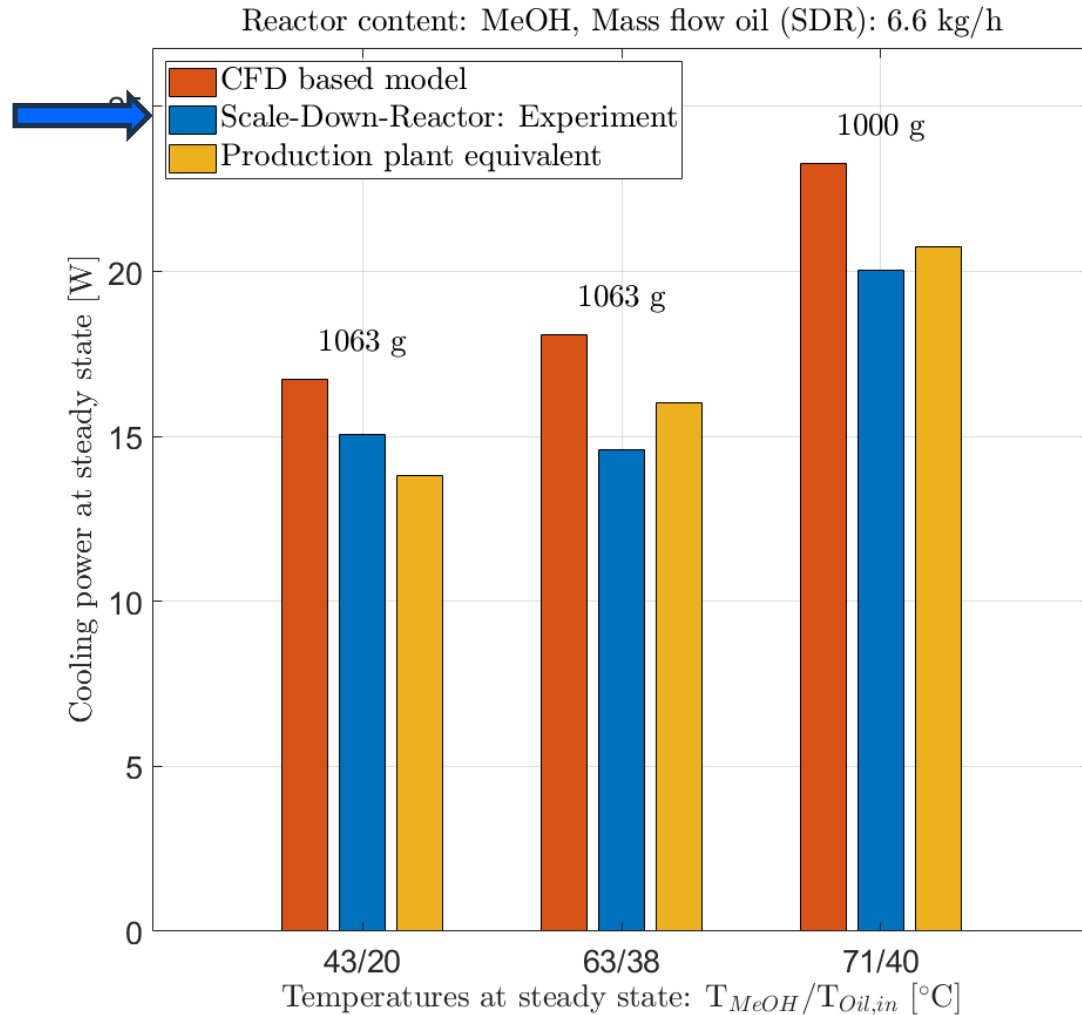

Workflow: Qualification of the H/C-Finger at steady state

Reactor content:
Methanol

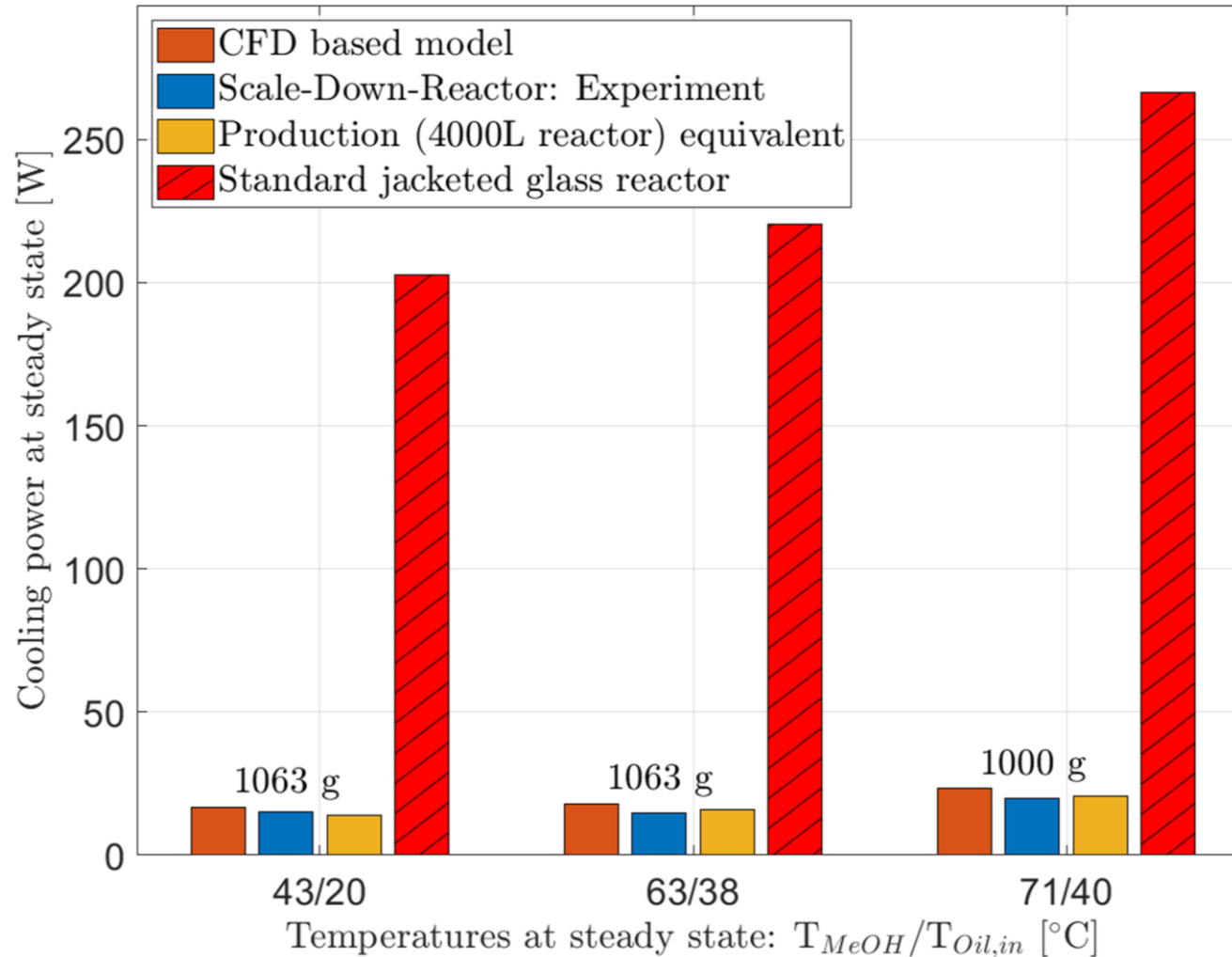

✓ The heat transfer of the Scale-Down-Reactor is similar to the production scale reactor.

✓ Standard jacketed laboratory reactors are not representative!

Application: Hydrogenation

4 m³ Autoclave

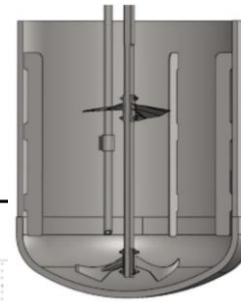

✓ The heat transfer of the Scale-Down-Reactor is similar to the production scale reactor.

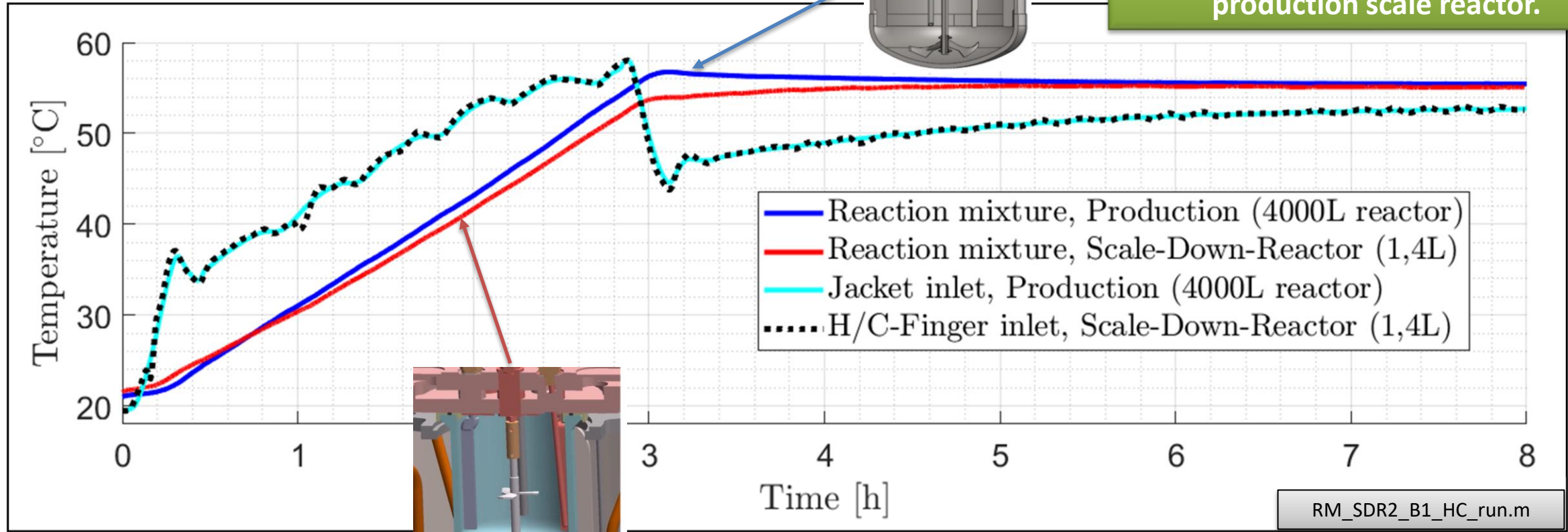

1 L Scale-Down Reactor

RM_SDR2_B1_HC_run.m

Outlook: Proposal for a future Scale-Up-Strategy

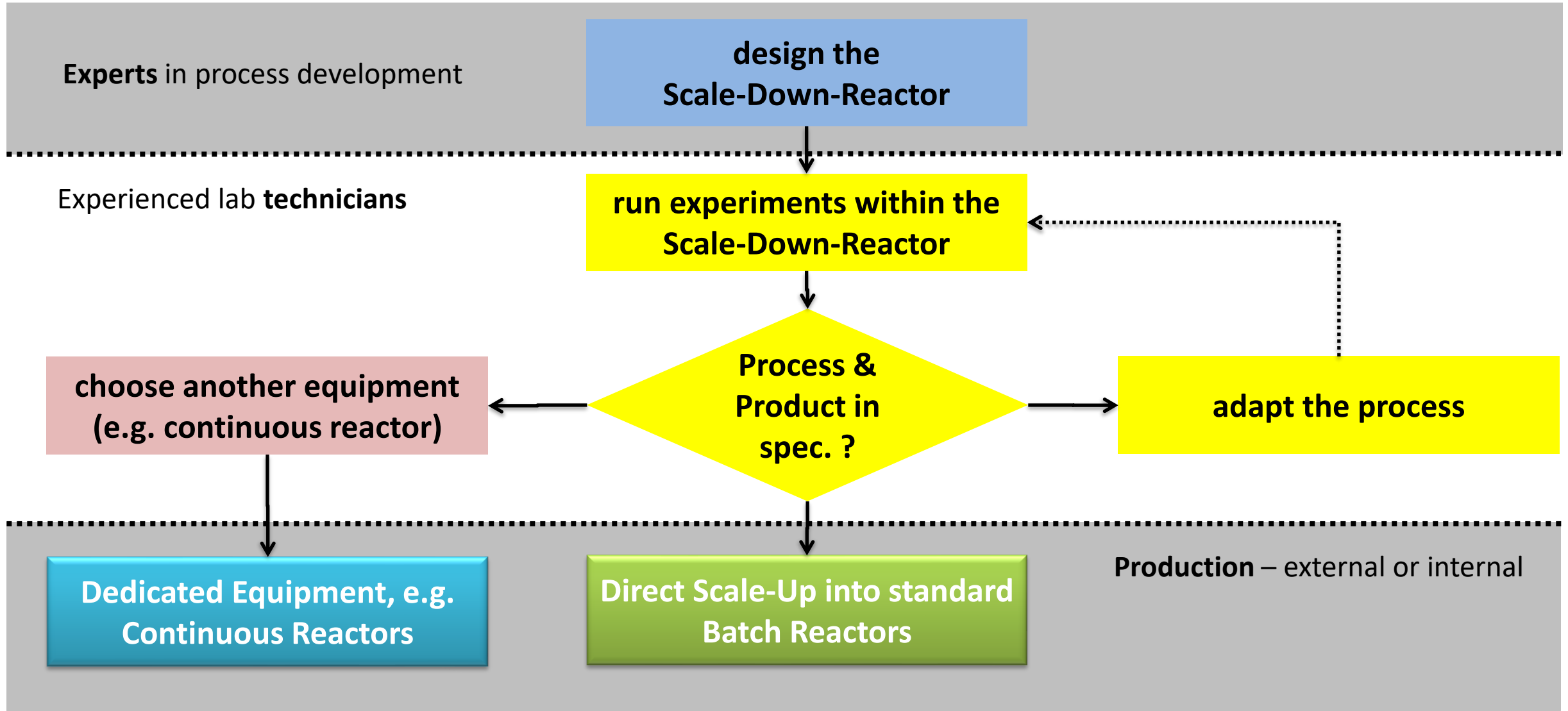

Heiz/Kühlfinger an der FHNW in Muttenz



Heiz-Kühlfinger optimiert bei der Siegfried AG



$T_{O,in}$

$T_{O,out}$

Siegfried

FERAMIC
3D METALLDRUCK

 **Allmetra**
measurement technology

Scale-Down Reaktor für Reaktionen unter Druck an der FHNW in Muttenz

Heiz-Kühlfinger eingebaut im RC1 bei der Siegfried AG

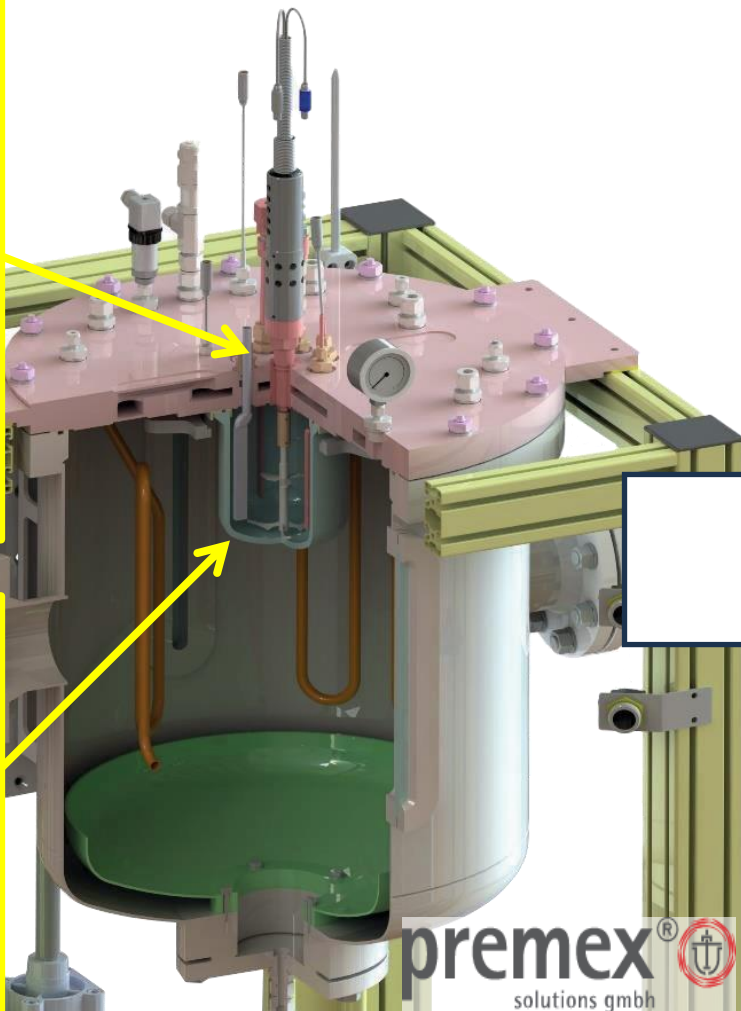
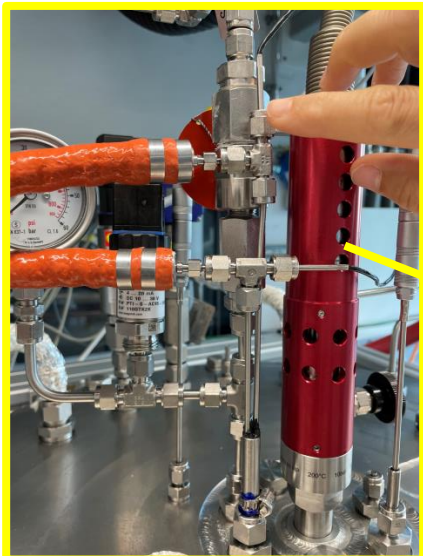

MiniPlant 4.0
Innovative Process Technology

premex[®]
solutions gmbh

n | w

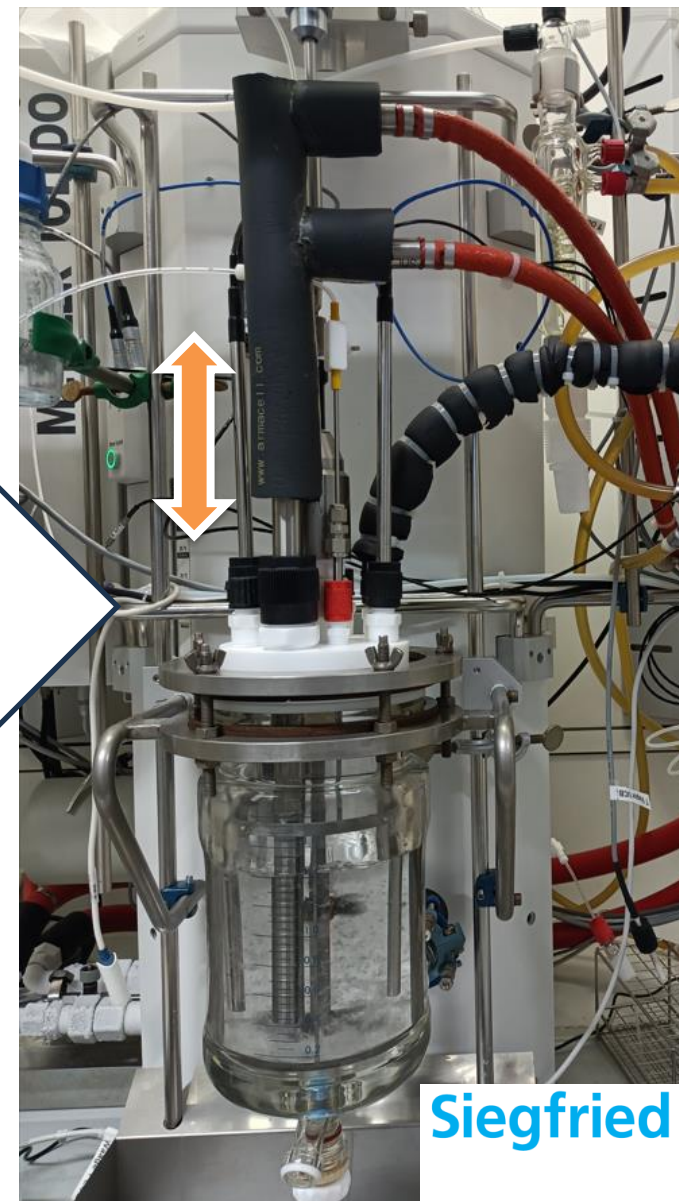

Siegfried

Scale-Down Reaktor für Reaktionen unter Druck an der FHNW in Muttenz

Heiz-Kühlfinger eingebaut In einen normalen Laborreaktor

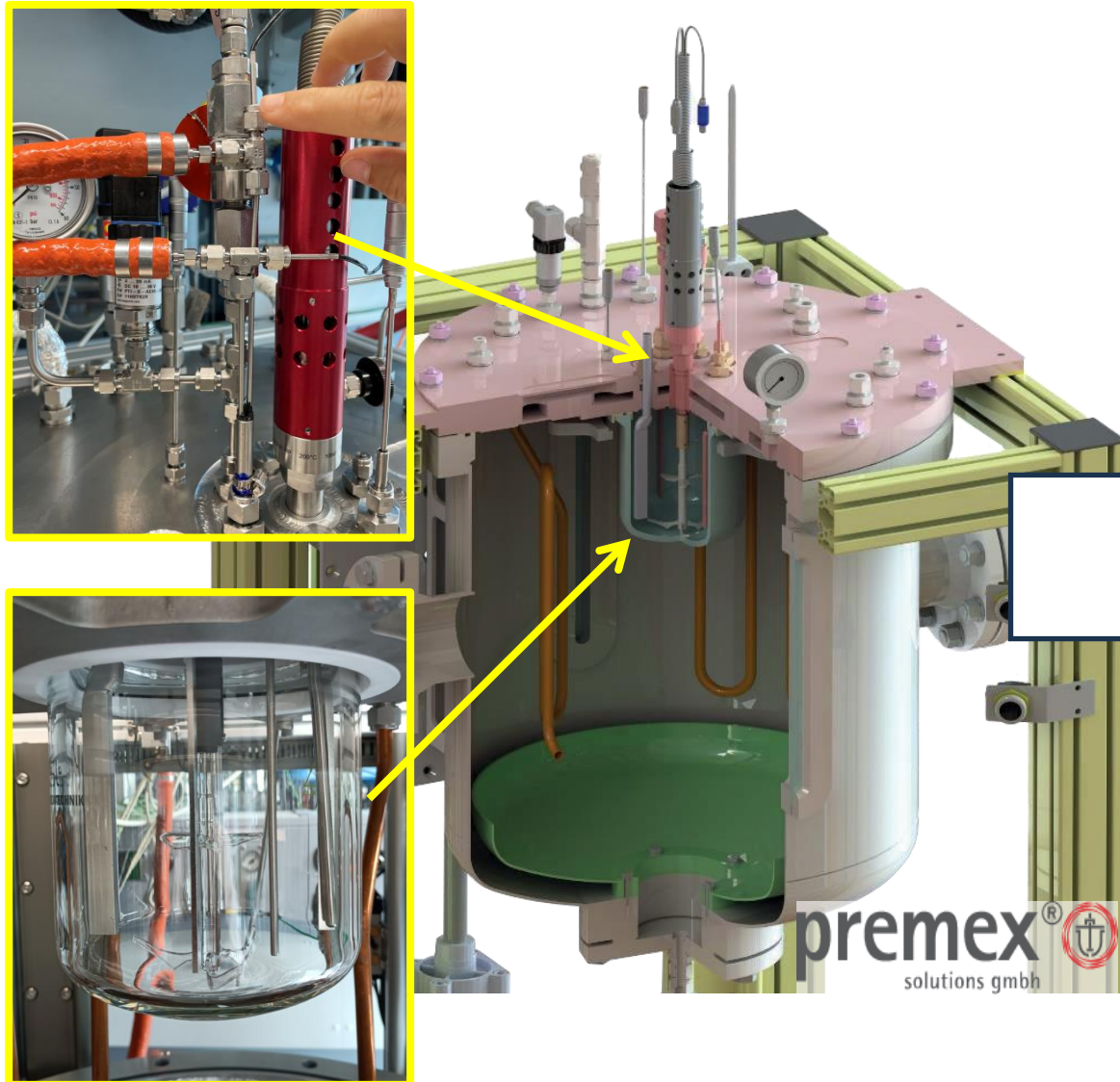

MiniPlant 4.0
Innovative Process Technology



GlasKeller

Mischthermostat für den Scale-Down Reaktor an der FHNW in Muttenz

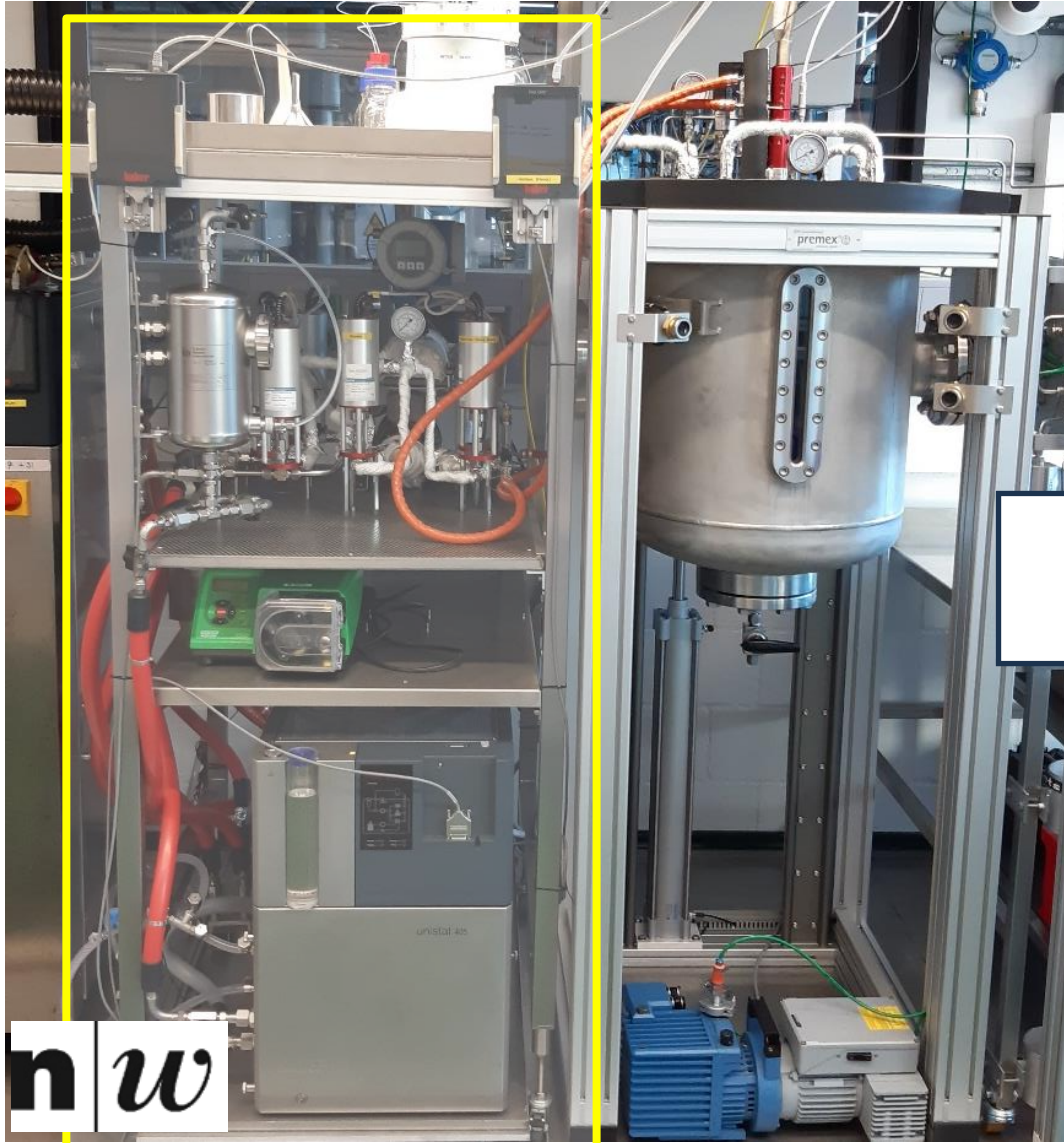

nw

Entwicklung eines kompakten Thermostaten für den H/K-Finger

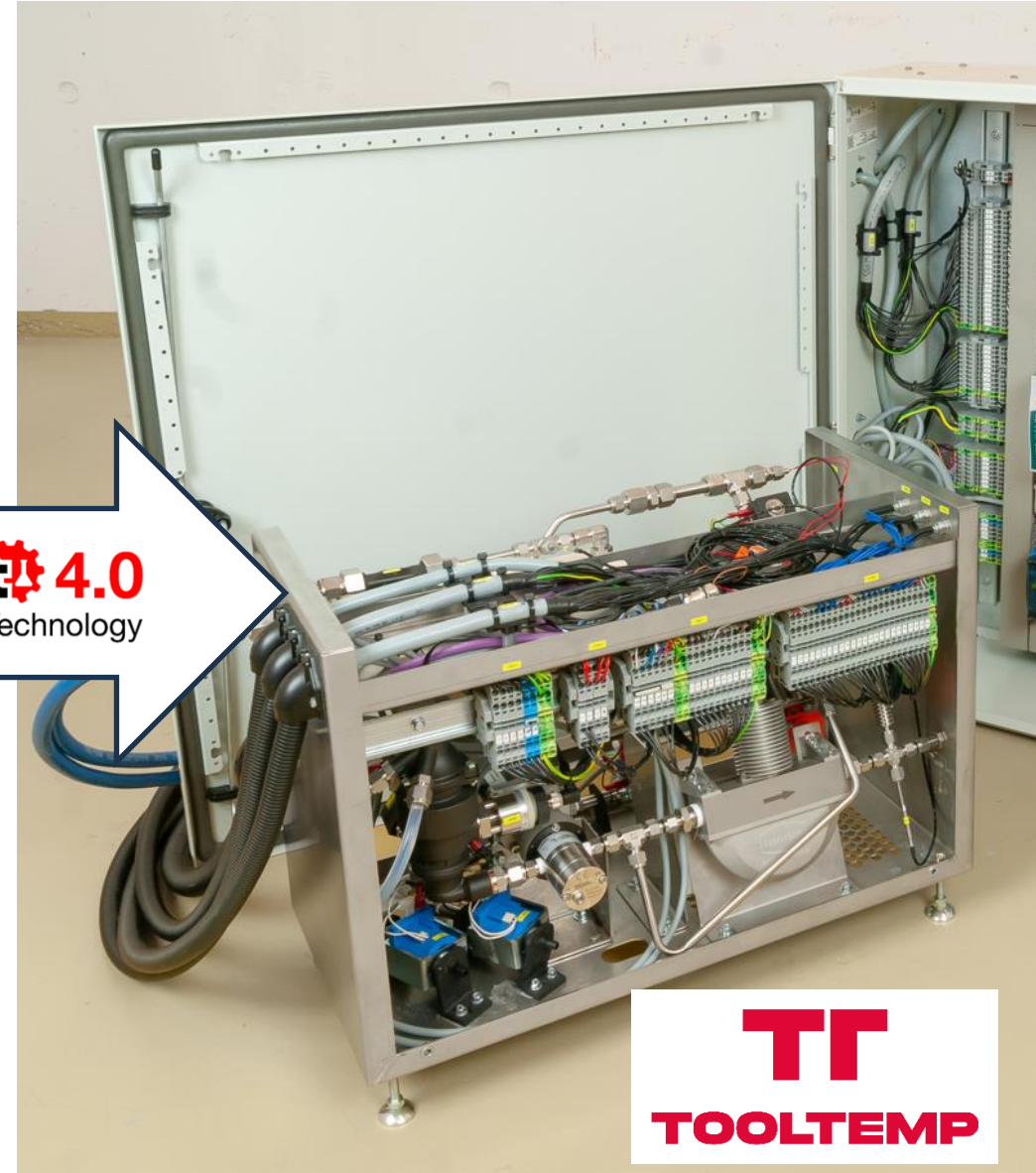

MiniPlant 4.0
Innovative Process Technology

TT
TOOLTEMP

Automatisierung des Scale-Down Reaktors an der FHNW in Muttenz

Vision

SPS



Lab supervision system

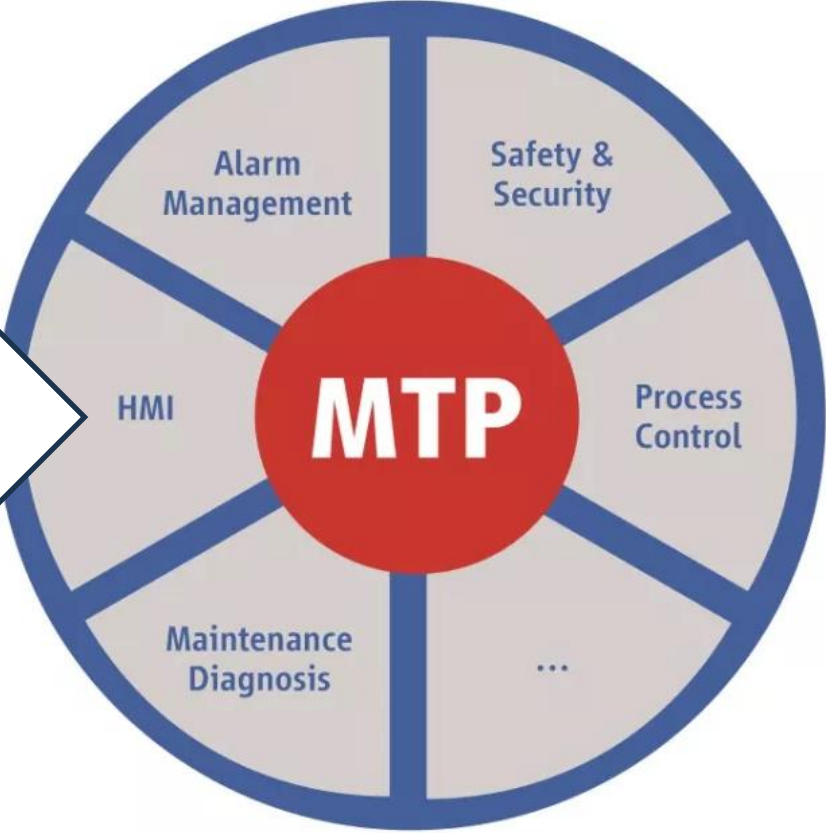
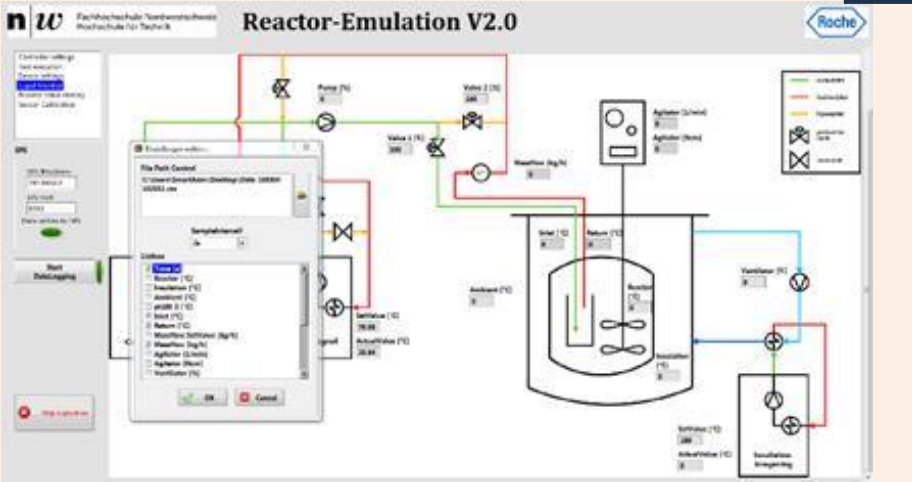

J rome Blum, Karl-Heinz Langendorf, Prof. Dr. David Zogg.



Vielen Dank

Siegfried

- ▶ Michael K. Levis
- ▶ Bernhard Berger
- ▶ Martina Hediger

Sponsoren:



- ▶ Marco Romanelli



Muttenz (HLS):

- ▶ Thierry Furrer
- ▶ Christoph Hasler
- ▶ Pavel Dagorov
- ▶ Benedikt Brönnimann
- ▶ Ronny Hardegger
- ▶ Gonzalo Álvarez
- ▶ This Zahnd
- ▶ Kai Wegmann
- ▶ Christian D. Maier
- ▶ Michael Teger
- ▶ Dario Mensing



Windisch (HT):

- ▶ David Zogg
- ▶ Daniel Weiss
- ▶ Weiqun Geng
- ▶ Jana Hoffmann
- ▶ Steffen Thierer
- ▶ Thomas Zbinden



- ▶ Benedikt Müller
- ▶ **ToolTemp:**
- ▶ Jonas Asprion
- ▶ Gianandrea Müller
- ▶ Nicola Rossi
- ▶ **Feramic**
- ▶ Martin Hofer
- ▶ **GlasKeller**
- ▶ Andreas Stubbe
- ▶ **Premex**
- ▶ Jürg Thut
- ▶ Hans-Peter Zbinden
- ▶ **Allmetra**
- ▶ Noah Burgunder