

# Kontinuierliche Ethoxylierung

Prof. Dr. Andreas Zogg  
This Zahnd, Benedikt Brönnimann

Pharma Forum 25.04.2024

[andreas.zogg@fhnw.ch](mailto:andreas.zogg@fhnw.ch),  
[this.zahnd@students.fhnw.ch](mailto:this.zahnd@students.fhnw.ch)  
[benedikt.broennimann@students.fhnw.ch](mailto:benedikt.broennimann@students.fhnw.ch)

<https://www.fhnw.ch/plattformen/miniplant40/continuous-ethoxylation/>

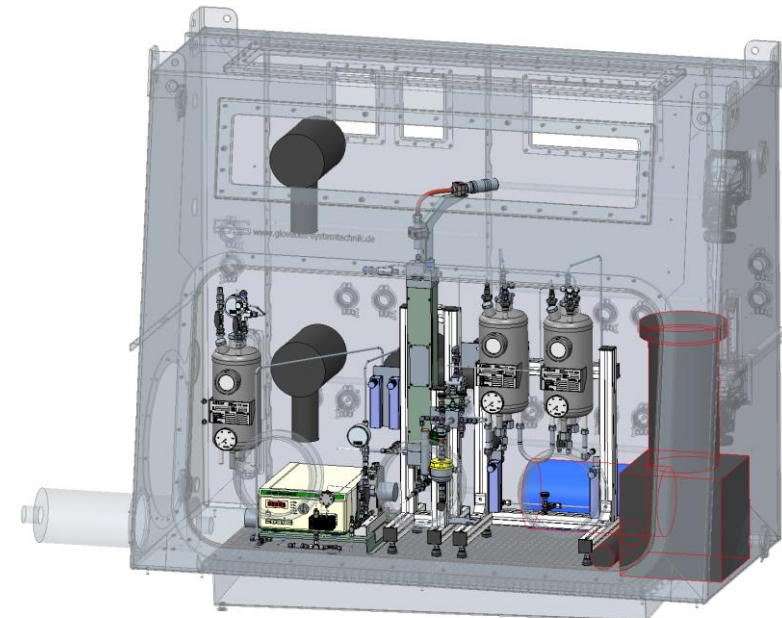
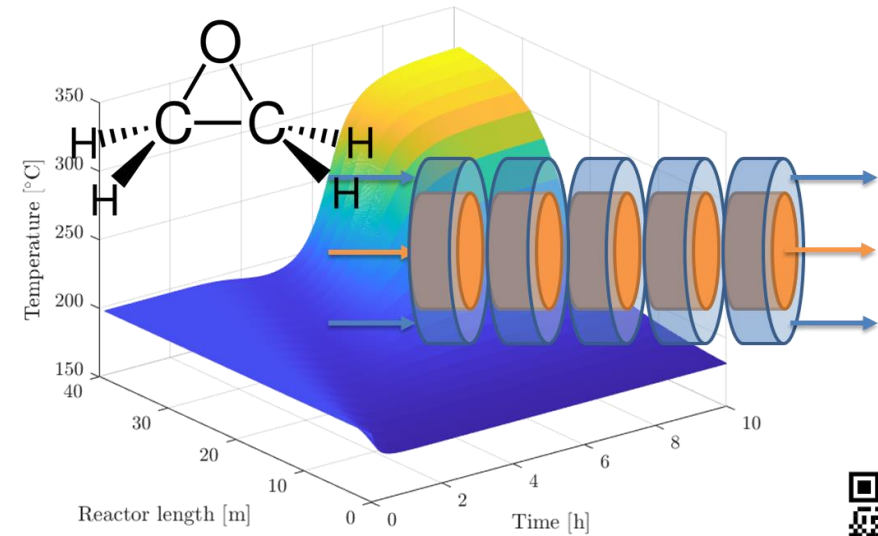

# Miniplant 4.0: Ein Think-Tank mit folgenden Zielen

1. **Ausbildung von Fachkräften** für Berufe in den Bereichen der:
  - **Verfahrensentwicklung**
  - **Verfahrenstechnik**
  - **Automatisierung**
  - **Chemical Engineering**
2. Entwicklung von **innovativen neuen Miniplants** für die:
  - **Verfahrensentwicklung**
  - **Produktion von Kleinmengen**
3. Wahrung des **intellektuellen Eigentums** aller Beteiligten – **ohne Patente.**



<https://www.fhnw.ch/plattformen/icb/miniplant40/>

# Miniplant 4.0: Aktuelle Projekte und Mitglieder

## Kontinuierliche Ethoxylierung



<https://www.fhnw.ch/plattformen/miniplant40/continuous-ethoxylation/>

**BUSS** ChemTech



## Scale-Down-Reaktor



<https://www.fhnw.ch/plattformen/icb/scale-down-reactor/>

## Digitalisierung für Miniplants

**SIEMENS**



# Einleitung: Ethoxylierung

Ethylenoxid = «EO»

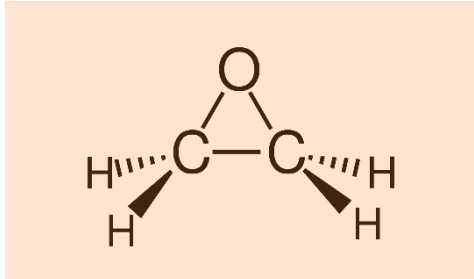

Weltweite Produktion  
im Jahr 2000  
≈ 15 Mio t/a



Anwendungen

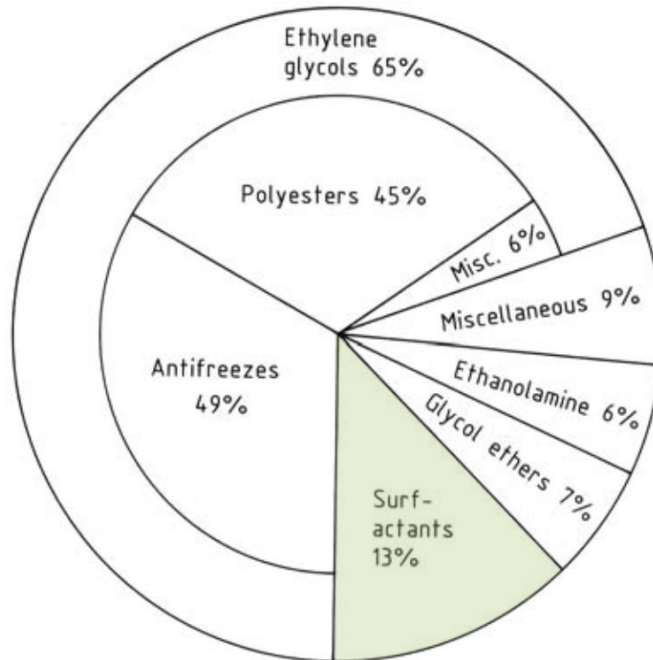

Tenside

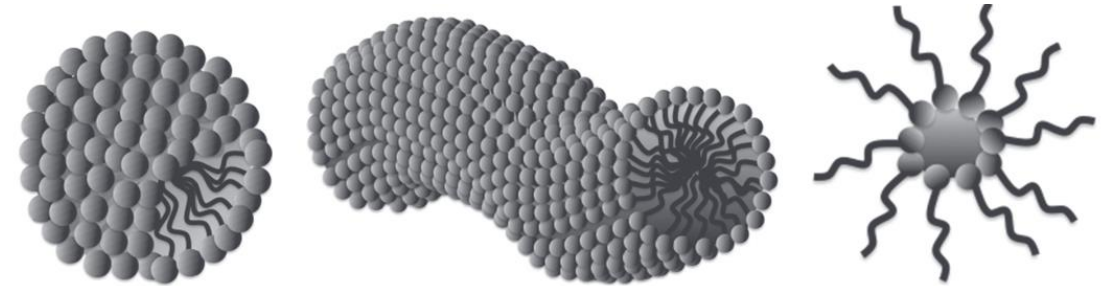

Anionische Tenside

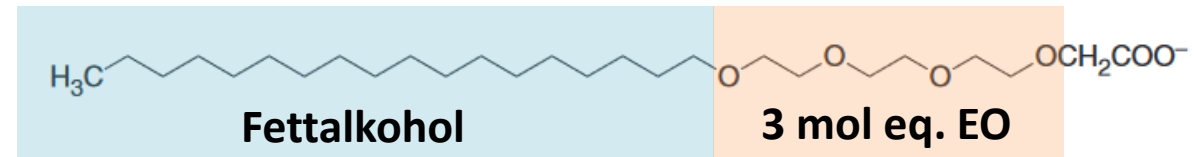

Nichtionische Tenside

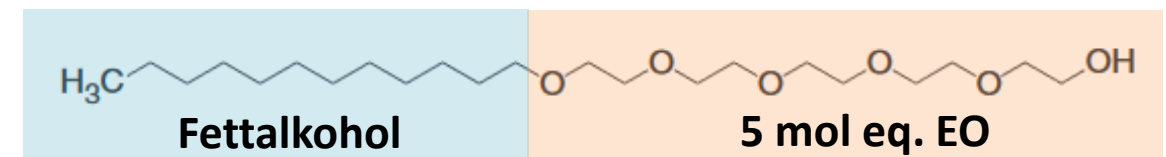

# Ethoxylierung: Aktuelle Prozesstechnik

## Semi-Batch-Anlagen

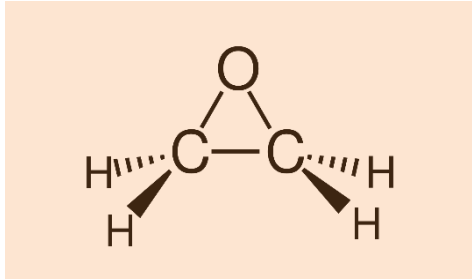

## Rührkessel

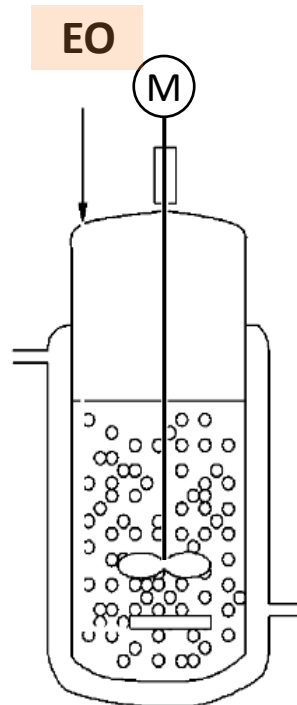

## Venturi Loop

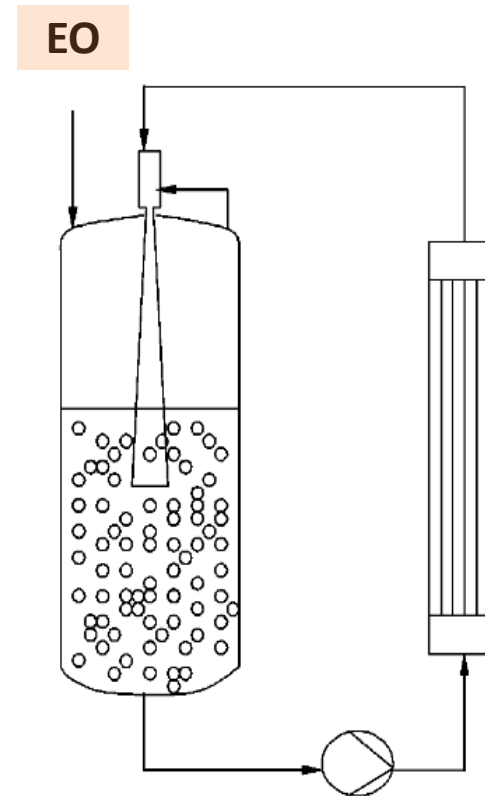

## Spray Loop

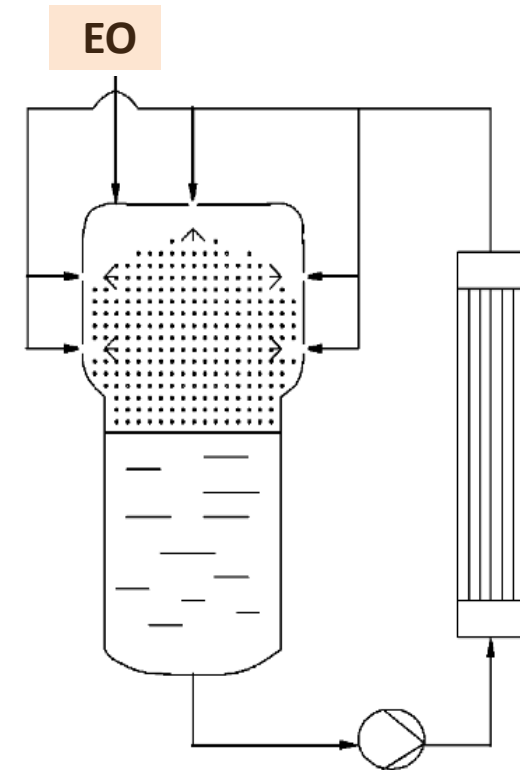

# Ethoxylierung: Aktuelle Prozesstechnik

14th of January 2020, Tarragona, Spanien

Among these batch type plants there is the unit U3100 where the explosion occurred during the production of the 7<sup>th</sup> batch of MPEG 500. MPEG 500 is used as additives for cement.



Figure 3-2: Unit 3100 prior to the explosion

QOXE plant



Figure 3-5: Excerpt from video showing the destroyed U3100 and surrounding facilities

# Ethoxylierung: Aktuelle Prozesstechnik



**Figure 3-6: Plotted missile fragments to IQOXE and surrounding plants**

Most of the fragments are located at the east of the plants. This happens because other directions were blocked by buildings in the IQOXE site itself. Around 40 fragments have been reported, some of them up to 400kg. Most of them were parts of the U3100 structure.

The incident occurred in the U3100 on the 14<sup>th</sup> January of 2020 at approx. 18:40.

Comparing the damage to the steel structure of U-3100 with the unit prior to the accident indicates a centre of an explosion located in the upper part of the reactor bay. The vertical structural steel has been forced away from the centre of the explosion.



**Figure 3-3: U3100 directly after the explosion**



**Figure 3-4: plate from reactor found in household in Torreforta**

# Innosuisse Projekt - Kontinuierliche Ethoxylierung



Umfang: 548'785.00 CHF  
Start: Juni 2022, Ende: Q2 2025



Detail Design, Apparatebau und  
Projektleitung



Produktionserfahrung, Analytik  
Interesse an kommerzieller Anwendung

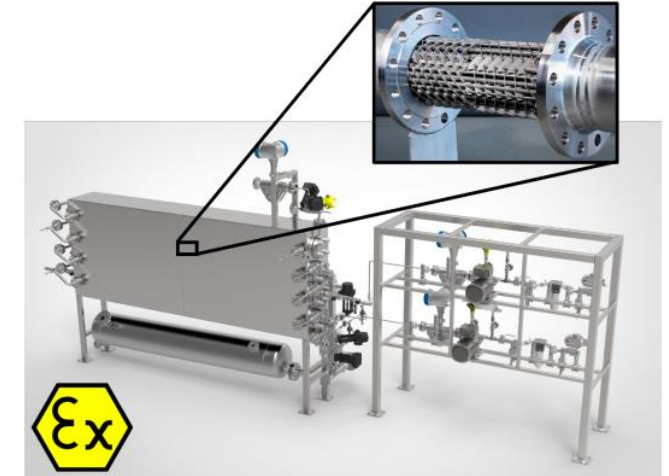

Erfahrung in der **chemischen Verfahrensentwicklung** und im Basic-Design von **Miniplantanlagen**

- ➔ Selbstständiges Design und Inbetriebnahme der **Sicherheits-Glove-Box**
- ➔ **Simulationsbasiertes Sicherheitskonzept** für gesamte Anlage
- ➔ **Basic-Design** der kontinuierlichen Konti-EO-Anlage
- ➔ **Inbetriebnahme** und **Anwendungsversuche** an der FHNW

Zwei Master-Studenten mit  
Teilzeitanstellung an der FHNW

# Innosuisse Projekt - Kontinuierliche Ethoxylierung

## Sicherheits-Glove-Box:

- $N_2$ -Atmosphäre
- Raumüberwachung mit  $O_2$ - und EO-Sensor
- Integrierter **Sicherheitswäscher** für die Vernichtung von EO-Leckage-Dämpfen

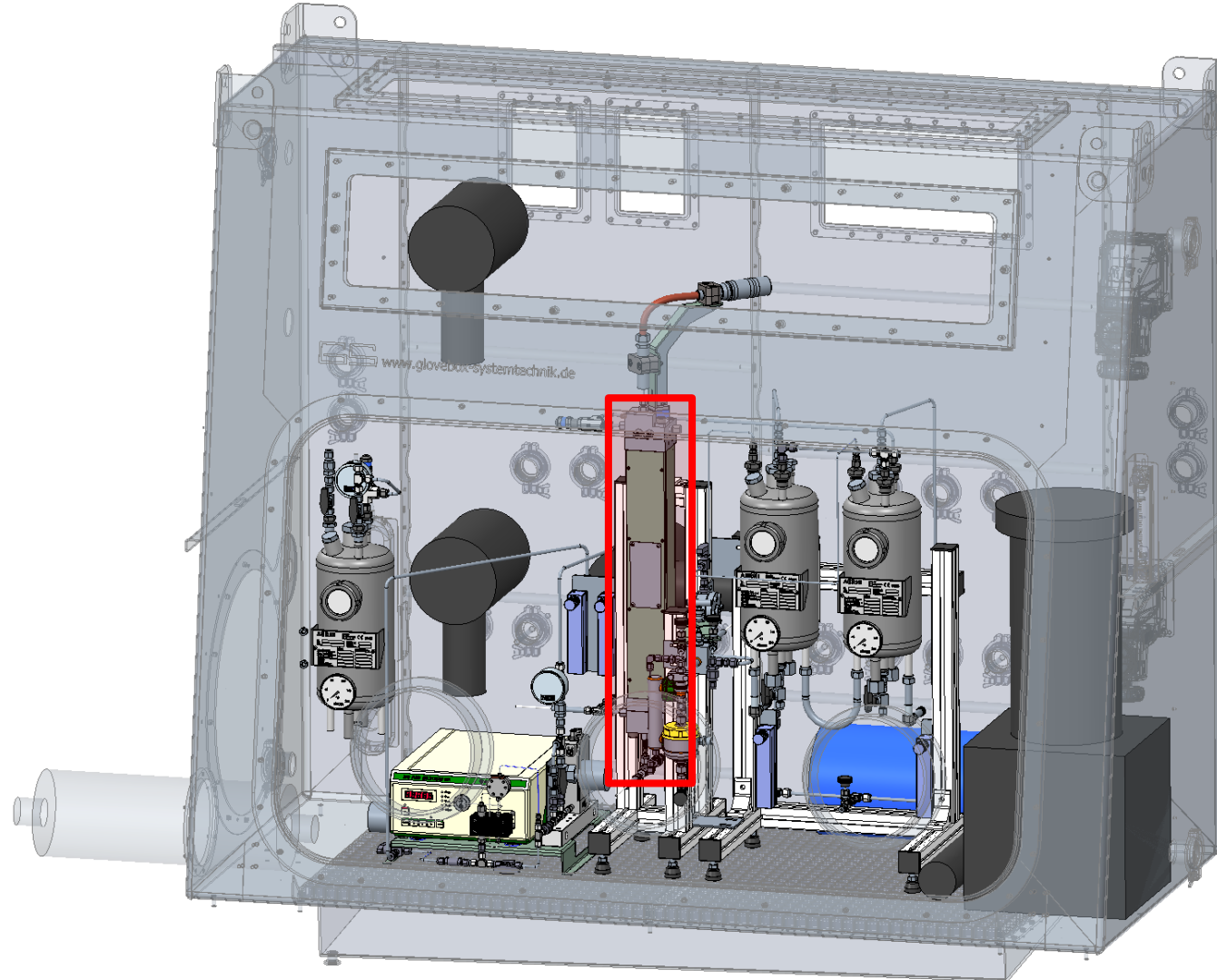

# Reaktormodell - Zielsetzung

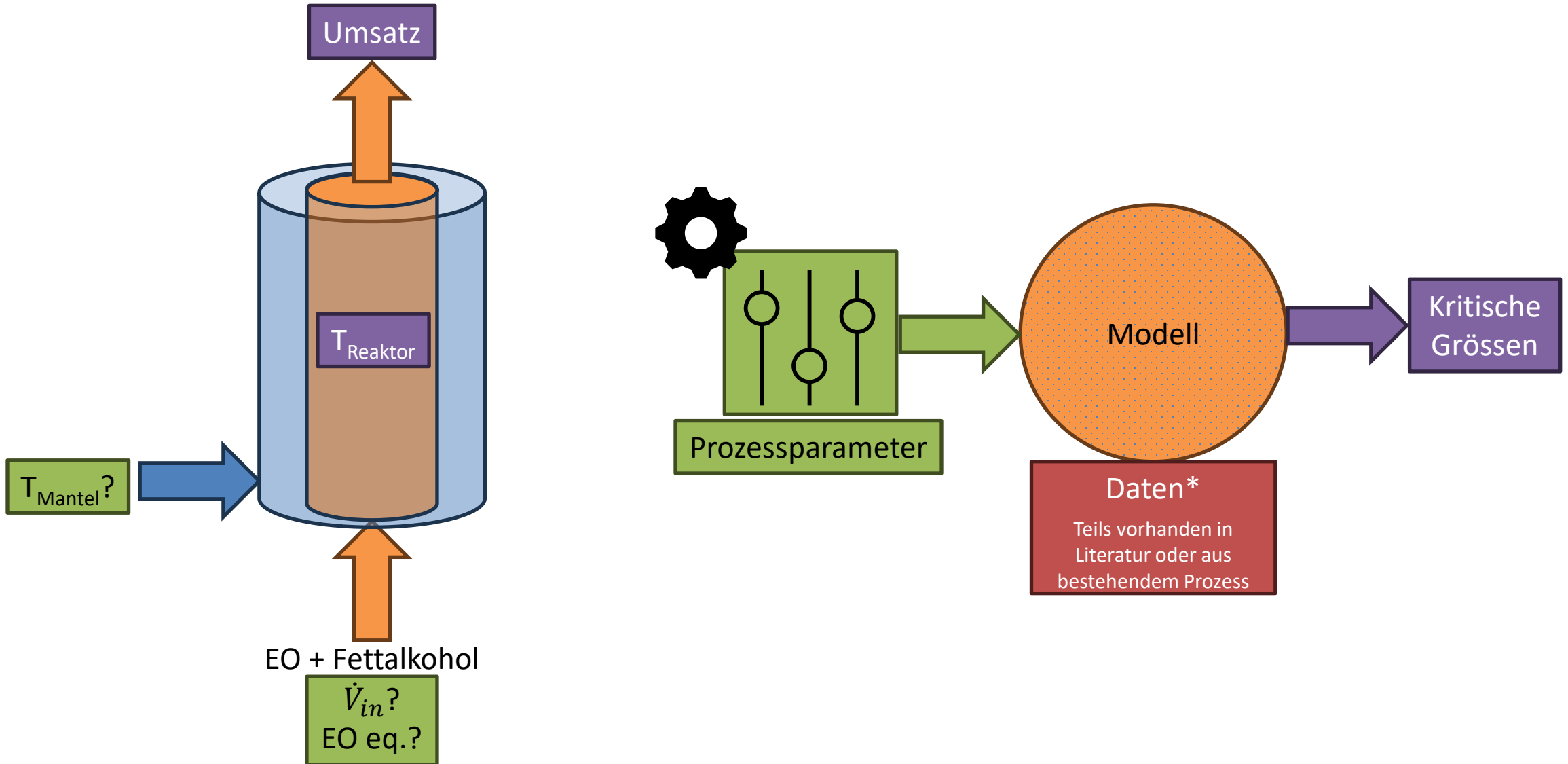

# Reaktormodell - Messdaten

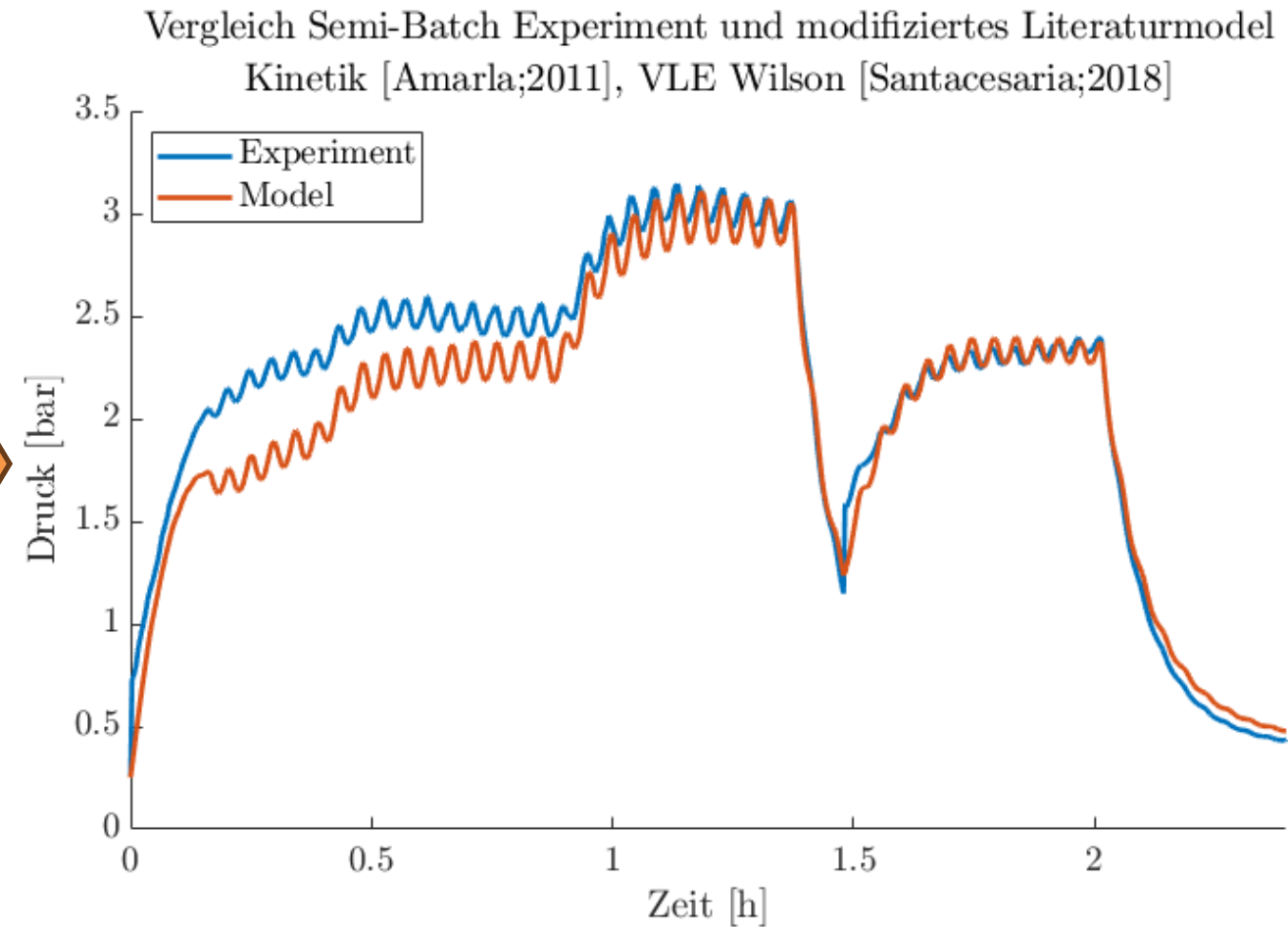
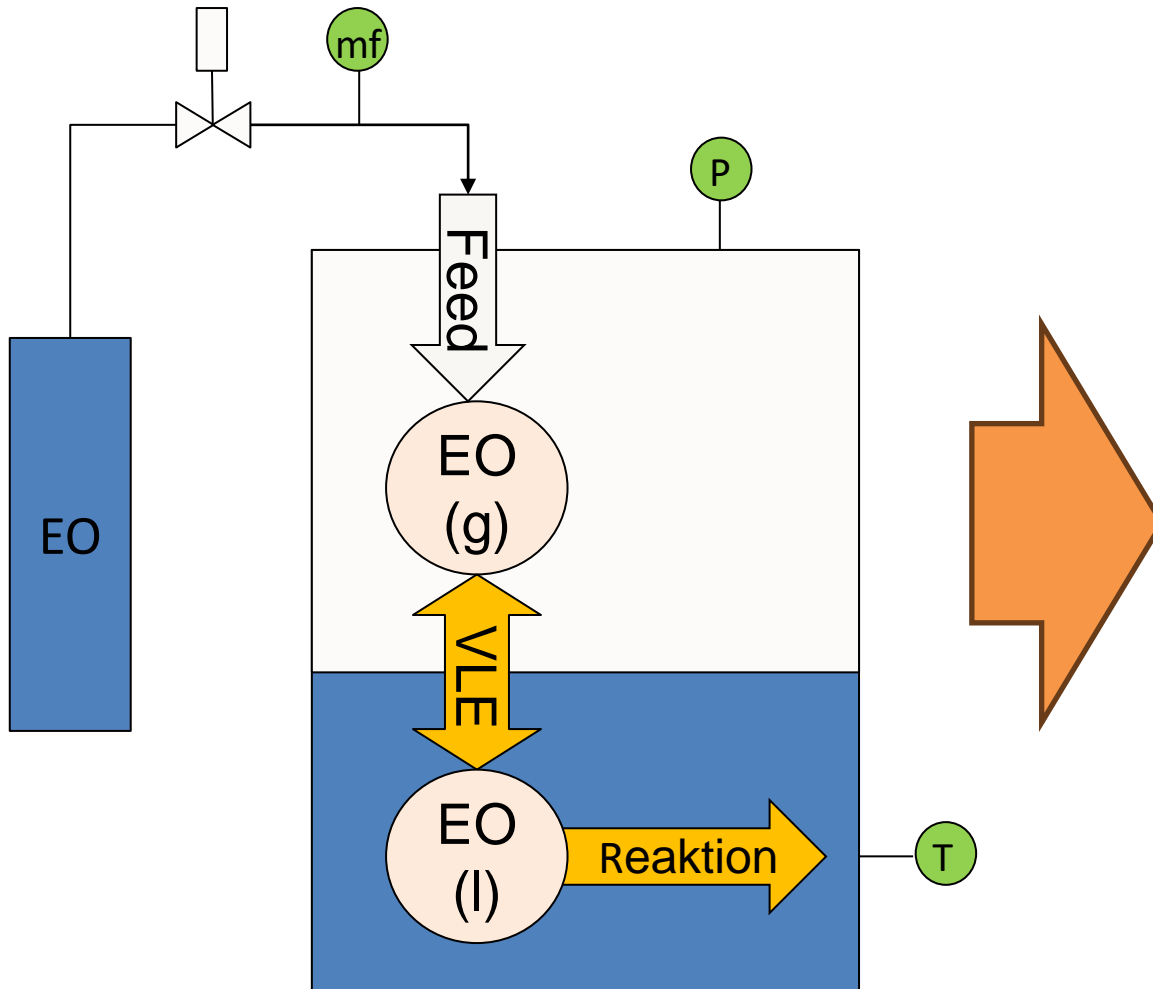

[Amarla;2011]: [10.1002/ceat.201290019](https://doi.org/10.1002/ceat.201290019)

[Santacesaria;2018]: [10.1016/j.cjche.2018.02.020](https://doi.org/10.1016/j.cjche.2018.02.020)

# Reaktormodell - Resultate

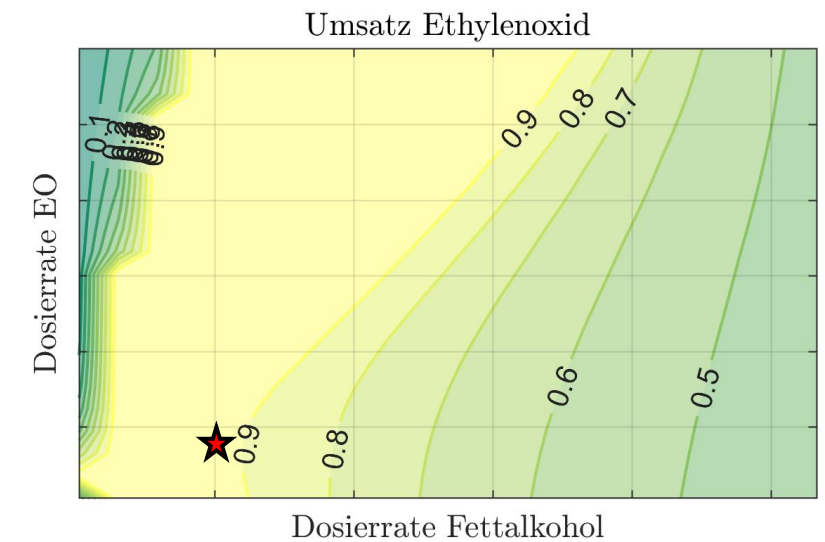
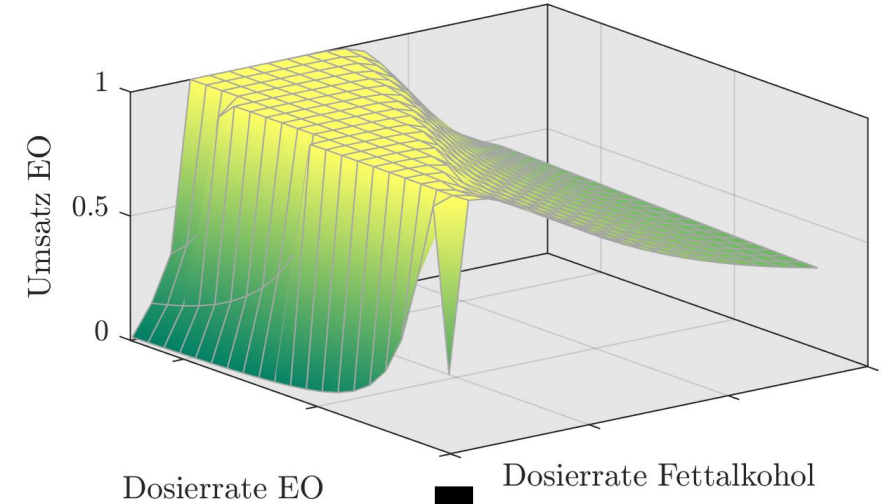
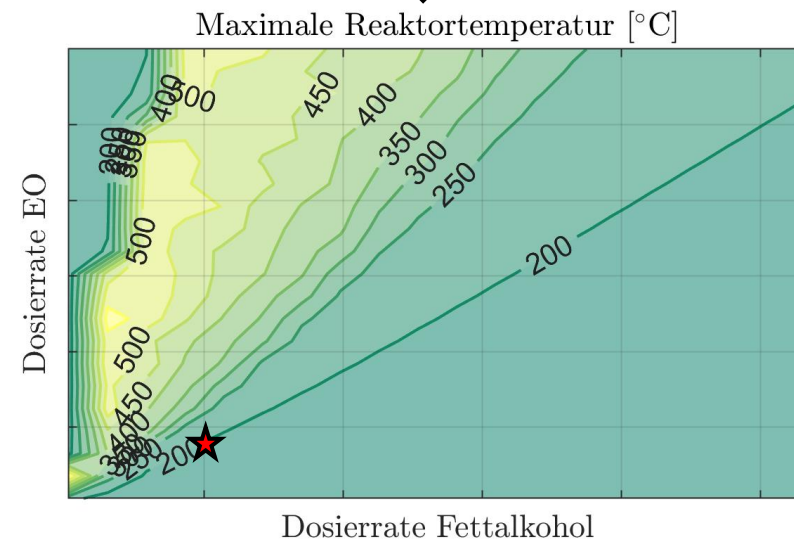
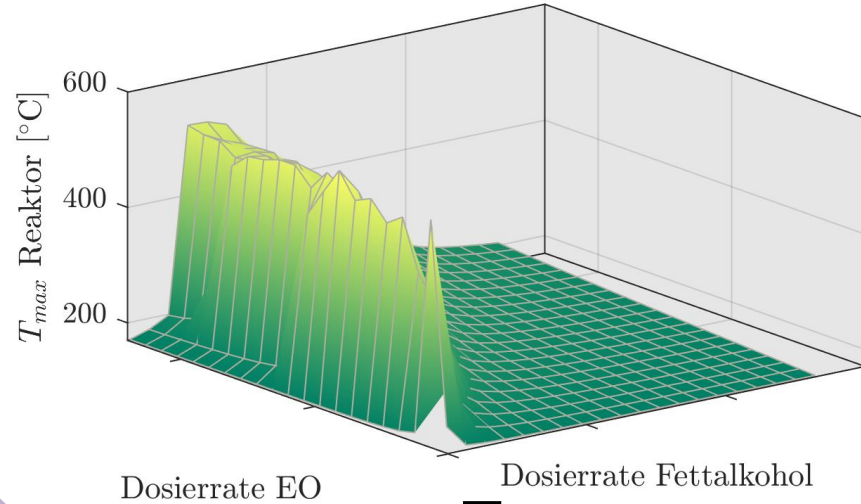
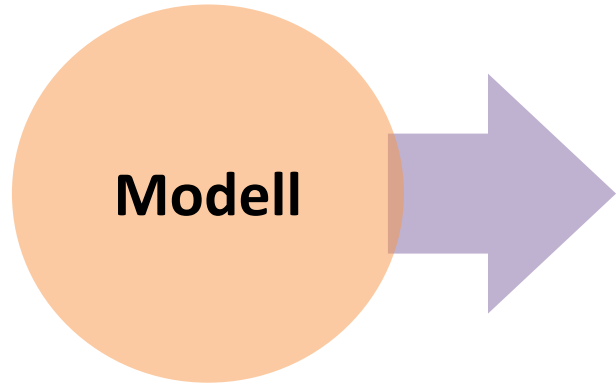

# Innosuisse Projekt - Kontinuierliche Ethoxylierung

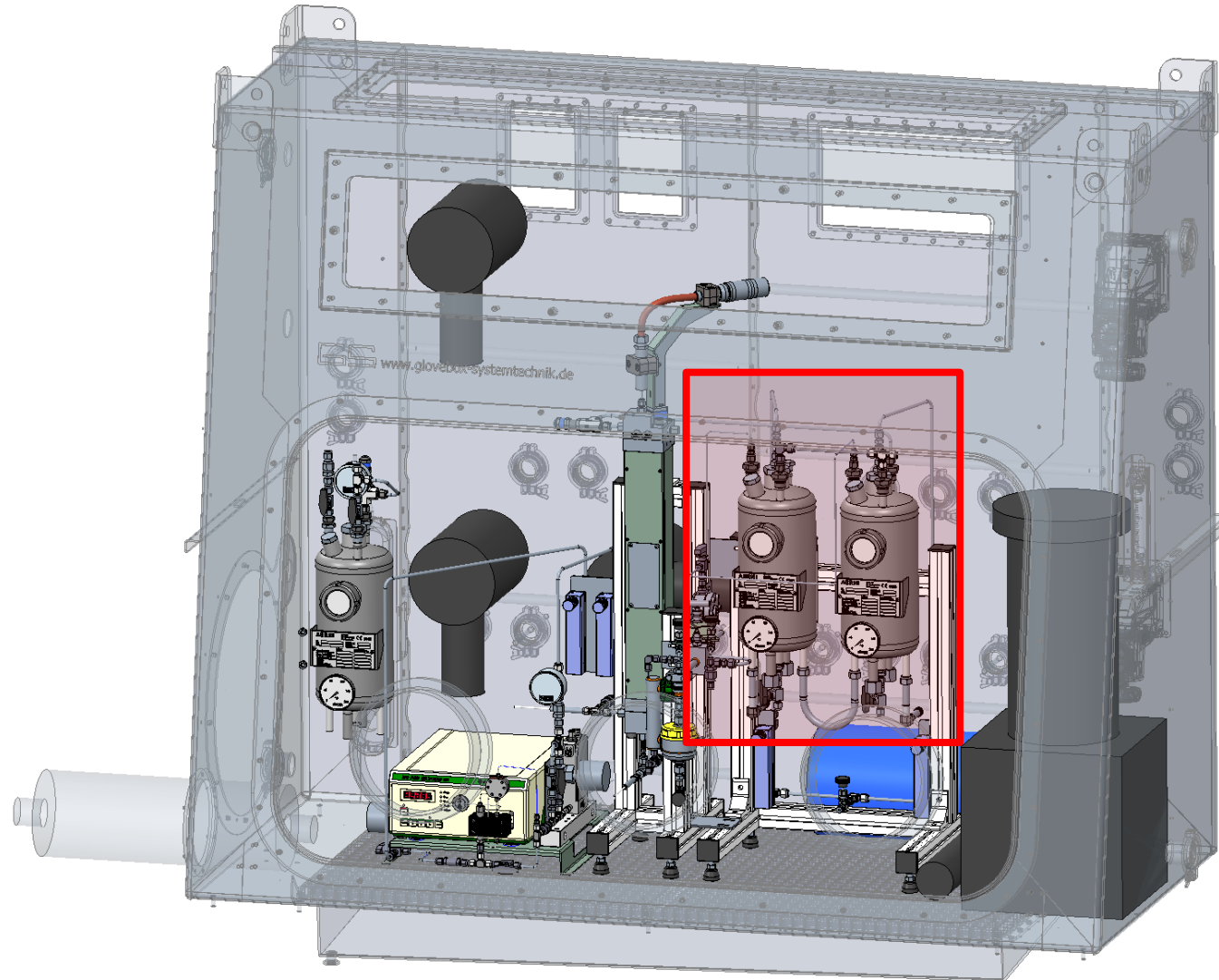

# Explosionsmodell - Szenario

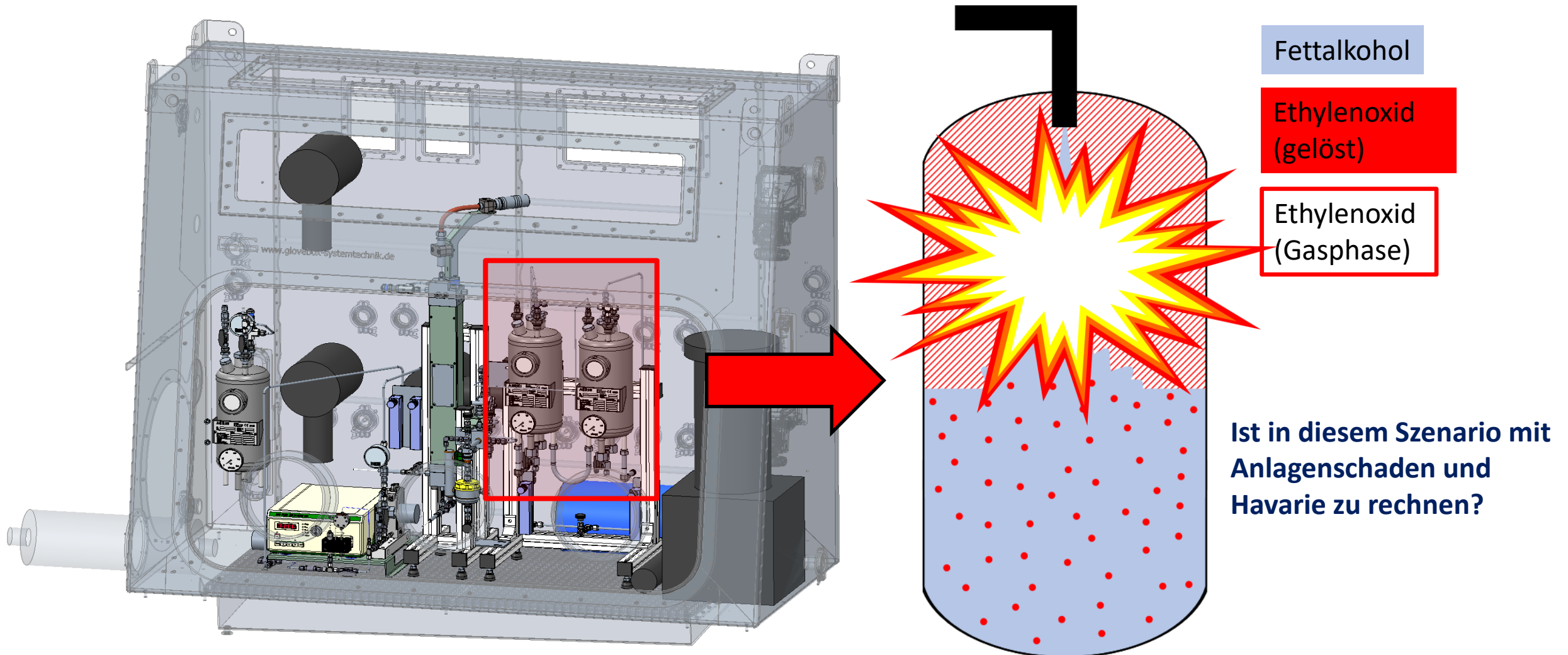

Fettalkohol

Ethylenoxid  
(gelöst)

Ethylenoxid  
(Gasphase)

Ist in diesem Szenario mit  
Anlagenschaden und  
Havarie zu rechnen?

# Explosionsmodell - Workflow

## Stoffdaten

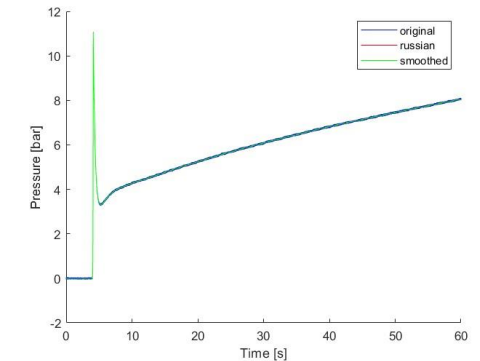
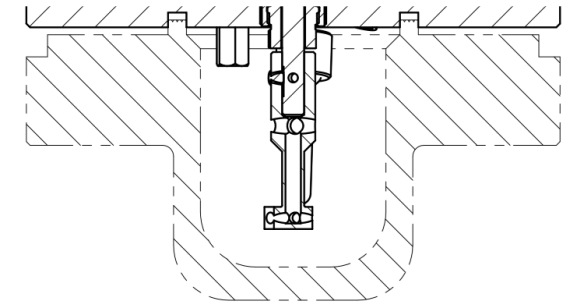
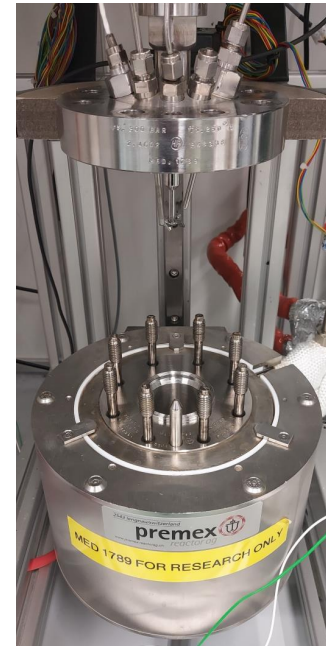
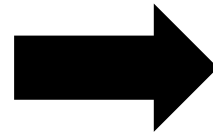
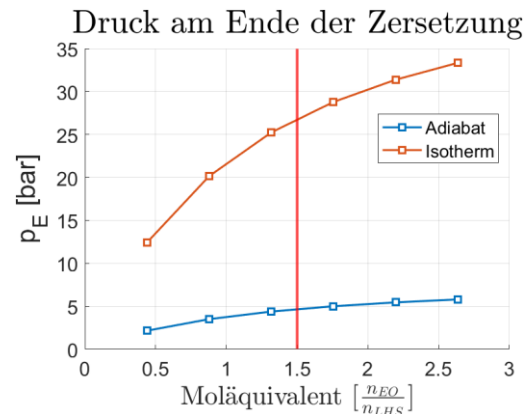

## Modell erstellen

## Laborversuch

# Explosionsmodell – Modellvorstellung und Resultate



Szenario A

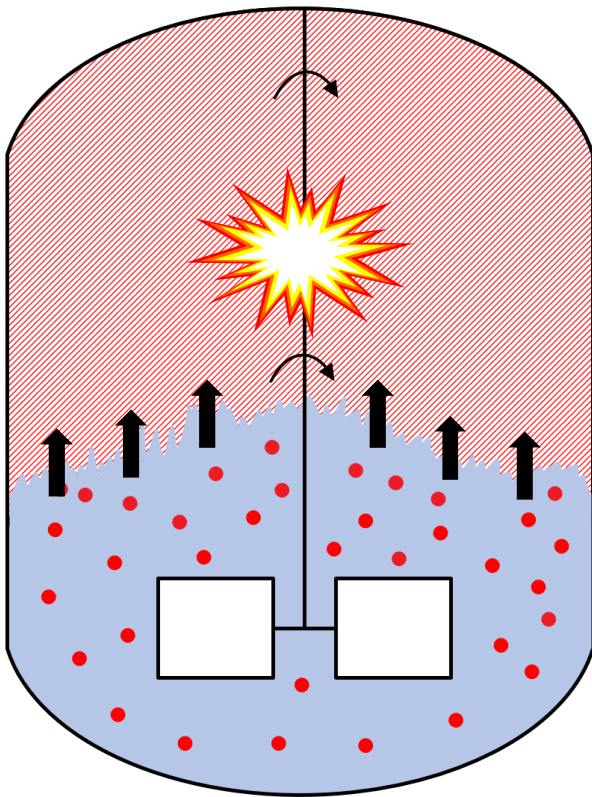

Szenario B

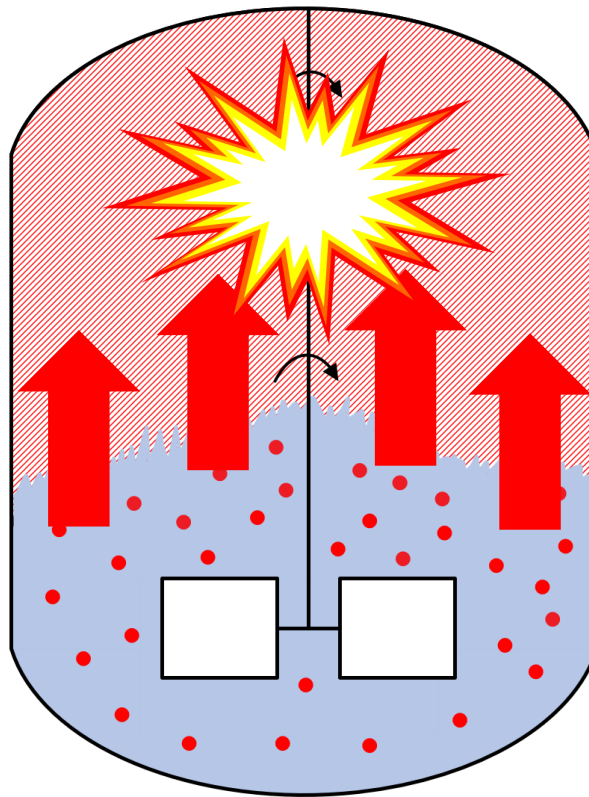

Explosionsdruck Modell

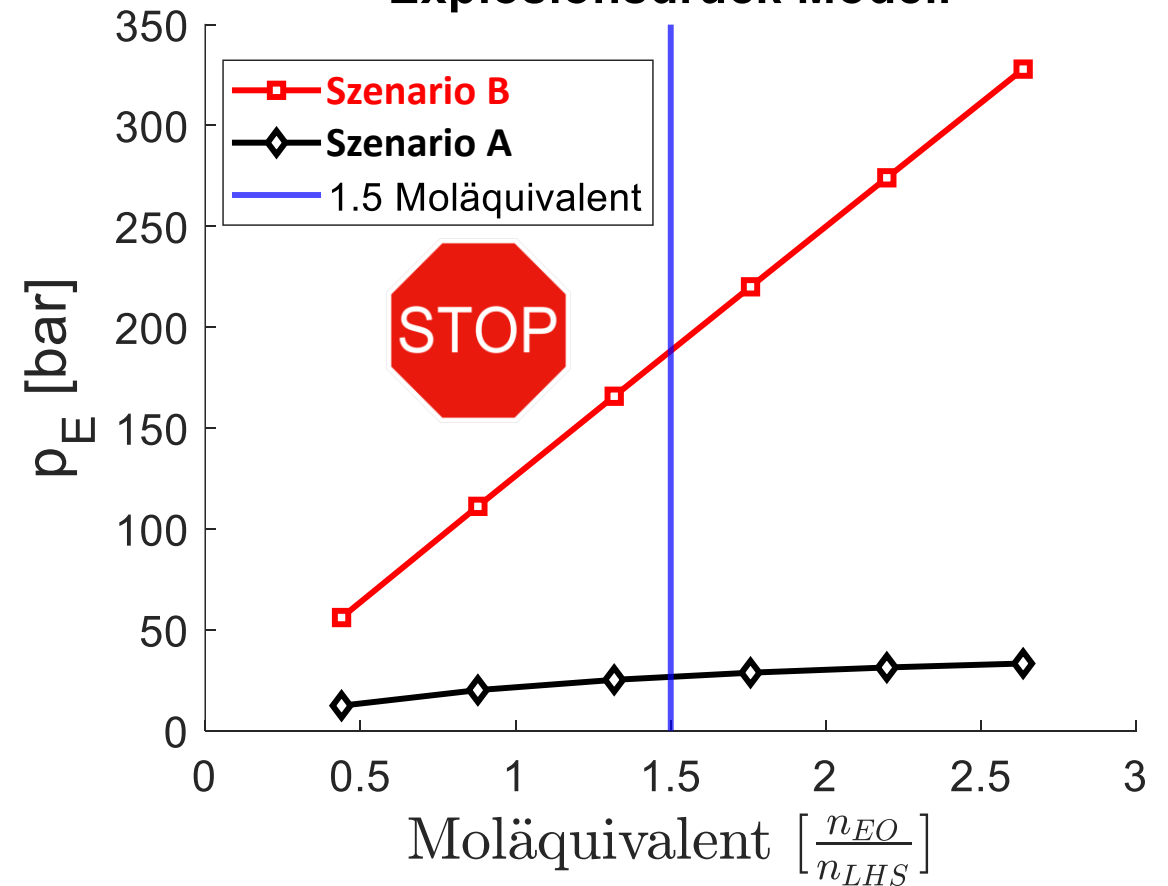

# Explosionsmodell – Reaktor und Messdaten

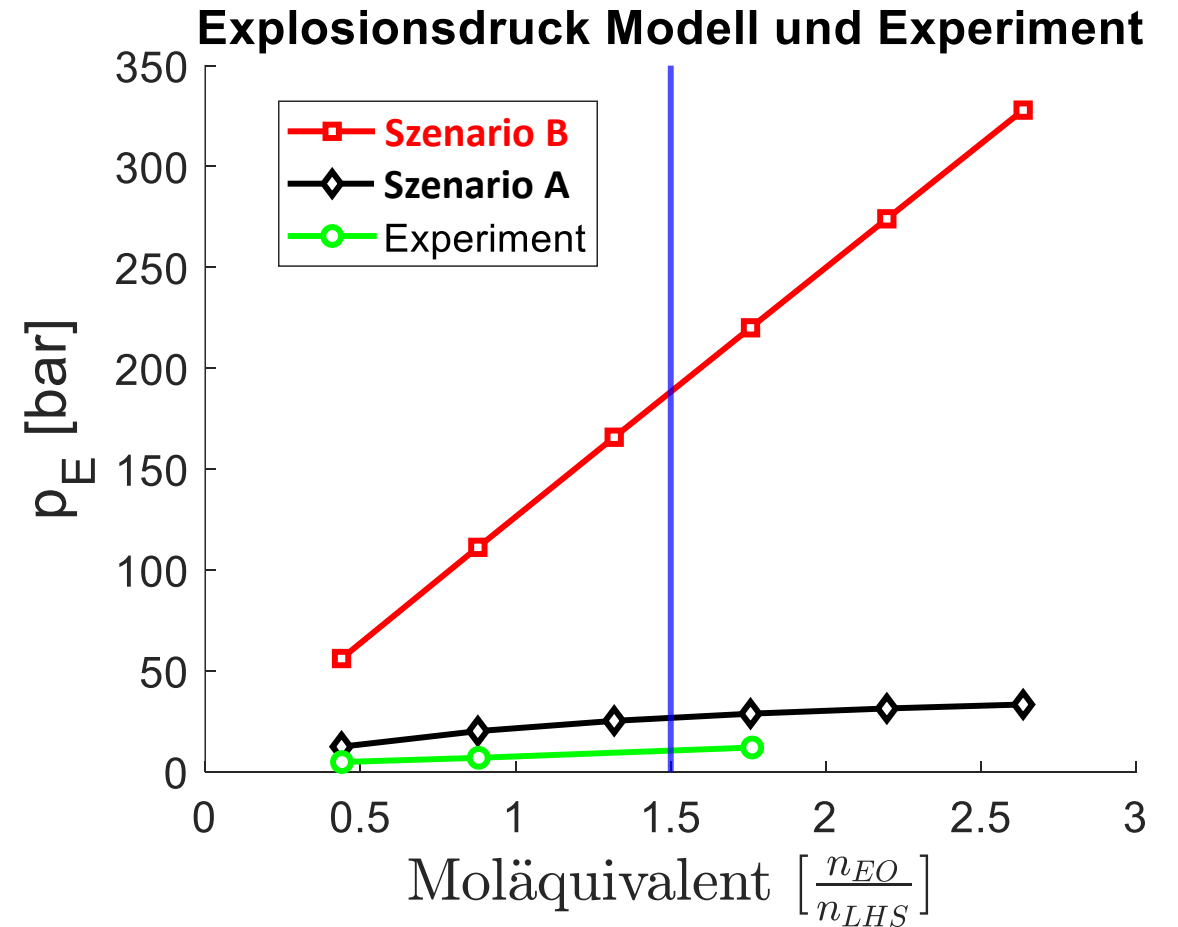
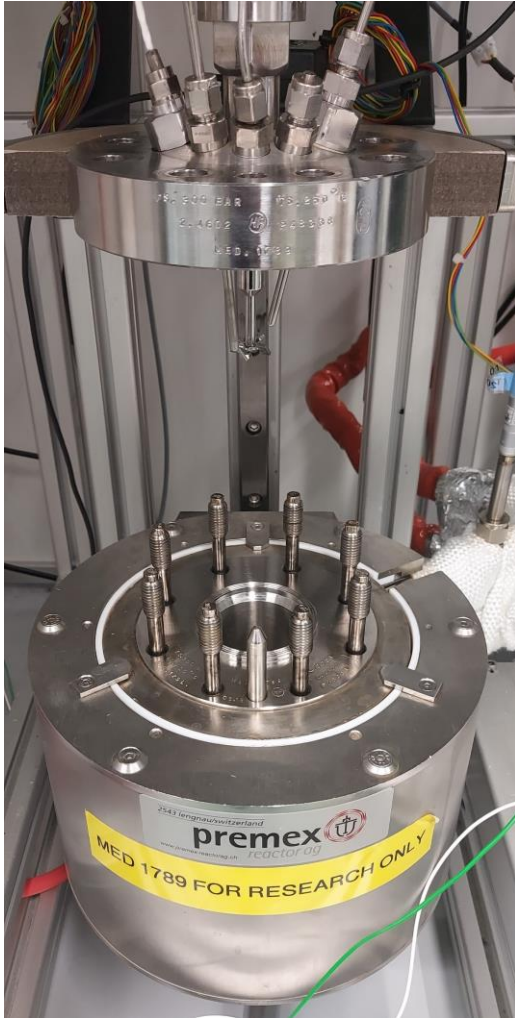

# Vielen Dank fürs Zuhören und an ...

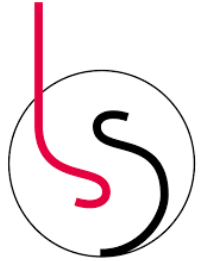

Schärer +  
Schläpfer

- ▶ Roland Borner
- ▶ Dieter Hübscher



- ▶ Marlies Moser
- ▶ Finn Steinemann
- ▶ Alain Georg
- ▶ Norbert Merkel
- ▶ Micha Hodler

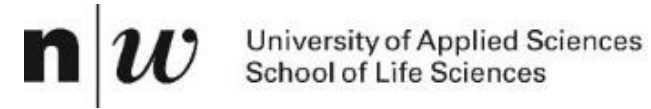

- ▶ Christoph Hasler
- ▶ Michael Teger
- ▶ Pavel Dagorov
- ▶ André Büttler

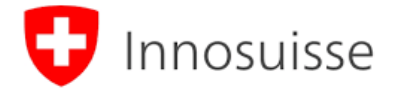

- ▶ Team Innosuisse

**Möchten Sie die Anlage bei uns im Labor sehen ... melden Sie sich in der Pause oder beim Apéro !**



**... oder besuchen Sie uns an der ...**

**ACHEMA2024**

**Halle 6.0, D5**

