

In this issue of *continent.*, which takes as its theme the idea of the moraine, or that which is left behind, we attempt to think, and look beyond that horizon of the possible cataclysm, not in naive ways of hope and gleeful sounds, but in an attempt to present different directions in thought and looking and hearing. Beyond the cataclysm, or within it—or even, precisely anterior to it (anterior to an event not yet happened)—there are new ways of thinking “beyond” already becoming apparent. These ideas are speculative, in a sense irresponsible: Graham Harman writes about Quentin Meillassoux’s God who does not exist now, but may do so in the future while Paul Ennis describes the speculative line backwards to Kant’s distinction between phenomena and noumena. Michael O’Rourke assesses the future of Queer Theory and we are compelled to ask if queer theory is a theory of everything. Karen Spaceinvaders “maps” the brain through sound leaving us to wonder where is the mind, while Phillip Stearns, as though echoing Spaceinvaders’ work, remaps digital photography, creating images from the stray electrical currents in the apparatus. In fiction, Ben Segal gathers the blurbs of the books yet possible. And there is more.

And so we proudly offer forth *continent.*’s second issue. Whereas issue 1.1 took the theme of isthmus (that which connects land to land, or even, throat to voice), in issue 1.2 we look at what remains after the crushing weight of slow, glacial time has passed. It is geological (which is genealogical) and it is archeological, but it is architectural too. In his later work, Heidegger describes the open (*das offen*) as a lightening (*lichtung*) in terms of a forest clearing which is not only “free for brightness and darkness, but also for resonance and echo, for sounding and diminishing sound. The clearing is the open for everything that is present and absent.”

In *continent.* 1.2, we imagine that clearing, that *lichtung* which is both a lightening and a clearing, a space of being from which to observe (or even participate in) the coming, very possibly banal, cataclysm(s).



Note from the Editors

by Nico Jenkins, Jamie Allen, Paul Boshears



Investigative Poetics: In (night)-Light of Akilah Oliver

by Feliz Molina

[READ \(/archives/issues/issue-1-2-2011/investigative-poetics-in-night-light-of-akilah-oliver\)](/archives/issues/issue-1-2-2011/investigative-poetics-in-night-light-of-akilah-oliver)

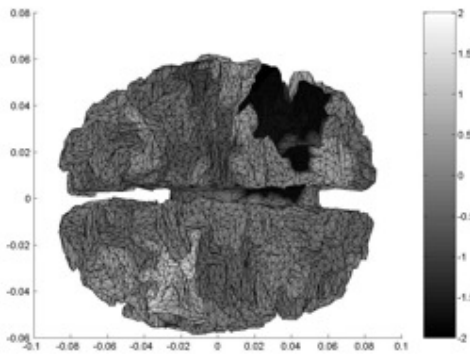

Please Mind the Gap: How To Podcast Your Brain

by Karen Spaccinva

[READ \(/archives/issues/issue-1-2-2011/please-mind-the-gap-how-to-podcast-your-brain\)](/archives/issues/issue-1-2-2011/please-mind-the-gap-how-to-podcast-your-brain)



Meillassoux's Virtual Future

by Graham Harman

[READ \(/archives/issues/issue-1-2-2011/meillassoux-s-virtual-future\)](/archives/issues/issue-1-2-2011/meillassoux-s-virtual-future)

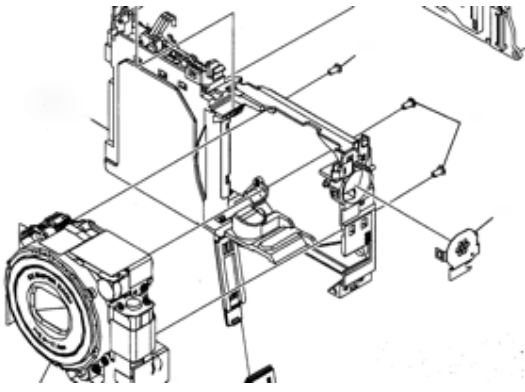

DCP Series
by Phil Stearns

[READ \(/archives/issues/issue-1-2-2011/dcp-series\)](/archives/issues/issue-1-2-2011/dcp-series)

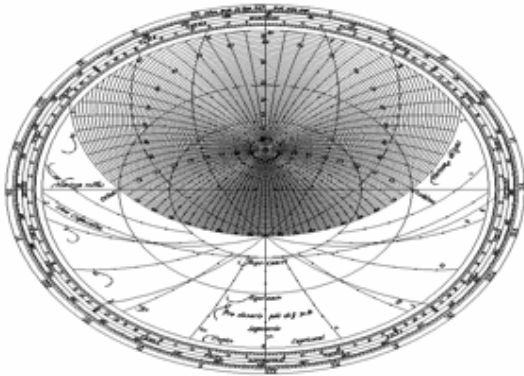

Copernican Metaphysics
by Paul Ennis

[READ \(/archives/issues/issue-1-2-2011/copernican-metaphysics\)](/archives/issues/issue-1-2-2011/copernican-metaphysics)



The Afterlives of Queer Theory
by Michael O'Rourke

[READ \(/archives/issues/issue-1-2-2011/the-afterlives-of-queer-theory\)](/archives/issues/issue-1-2-2011/the-afterlives-of-queer-theory)

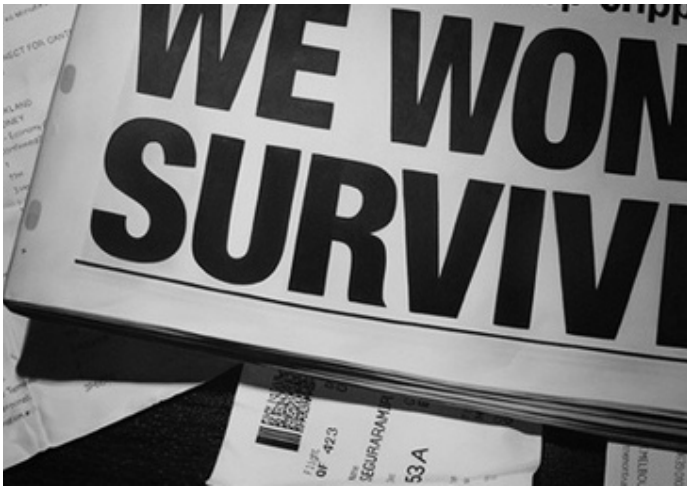

Gonzo Strategies of Deceit: An Interview with Joaquin Segura

by Brett W. Schulz [READ \(/archives/issues/issue-1-2-2011/gonzo-strategies-of-deceit-an-interview-with-joaquin-segura\)](/archives/issues/issue-1-2-2011/gonzo-strategies-of-deceit-an-interview-with-joaquin-segura)

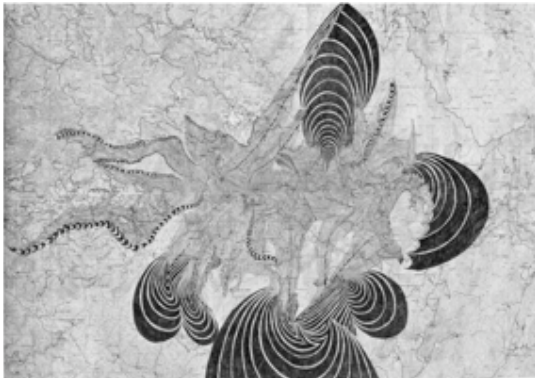

Orbital Contour: Videos by Craig Dongoski

by Paul Boshears [READ \(/archives/issues/issue-1-2-2011/orbital-contour-videos-by-craig-dongoski\)](/archives/issues/issue-1-2-2011/orbital-contour-videos-by-craig-dongoski)

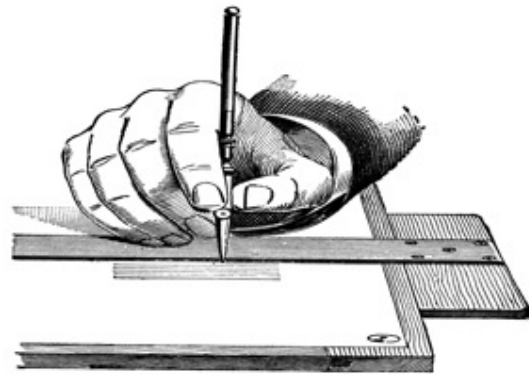

The Official Catalog of Potential Literature Selections

by Ben Segal [READ \(/archives/issues/issue-1-2-2011/the-official-catalog-of-potential-literature-selections\)](/archives/issues/issue-1-2-2011/the-official-catalog-of-potential-literature-selections)

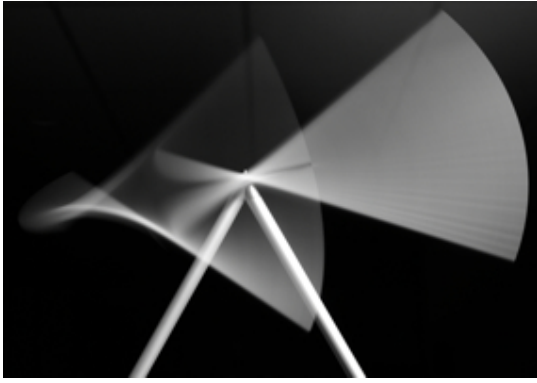

Remembering Robert Seydel

by Lauren Haaftorn-Schick, Sura Levine [READ \(/archives/issues/issue-1-2-2011/remembering-robert-seydel\)](/archives/issues/issue-1-2-2011/remembering-robert-seydel)



The Poetry of Nachoem M. Wijnberg

by Vincent W.J. van Gerwen O.J. [READ \(/archives/issues/issue-1-2-2011/the-poetry-of-nachoem-m-wijnberg\)](/archives/issues/issue-1-2-2011/the-poetry-of-nachoem-m-wijnberg)



Covering Giorgio Agamben's Nudities

by Gregory Kirk Murray [READ \(/archives/issues/issue-1-2-2011/covering-giorgio-agamben-s-nudities\)](/archives/issues/issue-1-2-2011/covering-giorgio-agamben-s-nudities)
